Theses and Dissertations

Summer 2010

Work zone safety intervention: perceptual countermeasure to speeding using synchronized warning lights

Sameer Ahmad Khan
University of Iowa

Follow this and additional works at: <https://ir.uiowa.edu/etd>



Part of the [Industrial Engineering Commons](#)

Copyright 2010 Sameer Ahmad Khan

This thesis is available at Iowa Research Online: <https://ir.uiowa.edu/etd/689>

Recommended Citation

Khan, Sameer Ahmad. "Work zone safety intervention: perceptual countermeasure to speeding using synchronized warning lights." MS (Master of Science) thesis, University of Iowa, 2010.
<https://doi.org/10.17077/etd.431lixus>

Follow this and additional works at: <https://ir.uiowa.edu/etd>



Part of the [Industrial Engineering Commons](#)

WORK ZONE SAFETY INTERVENTION: PERCEPTUAL COUNTERMEASURE TO
SPEEDING USING SYNCHRONIZED WARNING LIGHTS

by

Sameer Ahmad Khan

A thesis submitted in partial fulfillment
of the requirements for the Master of
Science degree in Industrial Engineering
in the Graduate College of
The University of Iowa

July 2010

Thesis Supervisor: Professor Lea-Der Chen

Copyright by
SAMEER AHMAD KHAN
2010
All Rights Reserved

Graduate College
The University of Iowa
Iowa City, Iowa

CERTIFICATE OF APPROVAL

MASTER'S THESIS

This is to certify that the Master's thesis of

Sameer Ahmad Khan

has been approved by the Examining
Committee for the thesis requirement for the
Master of Science degree in Industrial
Engineering at the July 2010 graduation.

Thesis Committee: _____

Lea-Der Chen, Thesis Supervisor

Daniel V. McGehee

Thomas Schnell

Michael Mackey

Dedicated to
Students abandoned by their advisors in the wake of their sorrow.

Reality is what we make of it.
It is what we conceive, it is what we perceive and it is the cyclic relation between
perception and conception.

Sameer A. Khan

ACKNOWLEDGMENTS

I am in great debt to Allah Who brought me into this world, Who ingrained in me a sense of righteousness and morality and Whose love is unbound. I am indebted to my mother, Professor Noorjahan Begum and my father, Jainul Abideen Khan for their unyielding care and support.

I would like to thank the faculty and staff of the Mechanical and Industrial Engineering Department of The University of Iowa for going out of their way to accommodate students' needs and aiding us in every way possible. I am really grateful to the members of the Cognitive Systems Laboratory at The University of Iowa – Dr. Bobbie Sepelt, Josh Hoffman, Michelle Reyes, Monica Lees, Jullie Ulland, Lora Yekhshatyan and Joonbum Lee for their feedback on this document from time to time and for being wonderful people to work with.

This thesis had its inception in a research project sponsored by the US Department of Health & Human Services, Centers for Disease Control & Prevention with the funds distributed through the University of Iowa Injury Prevention Research Center's Pilot Grant Program. In addition, funding was provided by the US Department of Transportation's University Transportation Center Program with funds distributed through the Midwest Transportation Consortium.

The larger part of the thesis was under the supervision of Professor John D. Lee, who was with The University of Iowa at the time. I am grateful to Professor Lee for his guidance and support. The fruition of the thesis was facilitated by Professor Lea-Der Chen, Head of the Department of Mechanical and Industrial Engineering at The University of Iowa. I am truly grateful to Professor Chen for his kind support in the final

leg of my master's program. I would like to acknowledge Professor Daniel McGehee, Professor Michael Mackey and Professor Thomas Schnell for their time and feedback. I would also like to thank Professor Rhonda DeCook, Department of Statistics and Actuarial Science at The University of Iowa, for her input on the statistical analyses of the collected data.

The credit of principal investigator and project management goes to Michelle Reyes, now with the Public Policy Center at The University of Iowa, who tenaciously helped deal with all the technical issues with the research and whose work ethics are an inspiration to me.

A great service as technical editor was provided by Melanie Laverman, College of Engineering, University of Iowa. I really appreciate her meticulous attention to details and providing the polishing touches to make this thesis more cogent and readable.

Last but not least, I would like to thank all my teachers, without whom I would not have been able to come this far.

ABSTRACT

A driving simulator study of perceptual countermeasures to speeding is described. Perceptual countermeasures (PC) manipulate the drivers' visual scene to help them moderate their driving speed without a conscious deliberation to do so. The use of synchronized warning lights in work zones as a PC is similar to airplane runway lights flashing toward the diver. Based on the literature survey, this effect was postulated to make drivers think they were driving fast at lower vehicular speeds with lesser speed fluctuations. The effect did not achieve statistical significance in reducing mean speeds within work zones to match the posted speed limit. A frequency domain analysis of driving speed fluctuation within work zones demonstrated that any form of flashing lights can have a pronounced effect on some individuals compared to static lights. The ramifications of using such perceptual countermeasures, which are currently being implemented around the world, are discussed.

TABLE OF CONTENTS

LIST OF TABLES.....	viii
LIST OF FIGURES.....	ix
INTRODUCTION	1
CHAPTER I BACKGROUND.....	4
Work zone safety issues.....	4
Work zones and work zone interventions.....	6
Speed regulation	7
Path diversion	8
Work zone illumination.....	11
General regulatory measures	14
Gaps in empirical research.....	16
Perceptual countermeasures.....	18
Underlying theory of perceptual countermeasures	20
Determining valid values of flash rate – f	23
Apparent motion of lit beacons	23
Determining valid values of distance – x	24
Determining valid values of time delay – t	25
Calculating edge rate – E.....	26
Summary.....	33
CHAPTER II HYPOTHESIS	34
CHAPTER III METHOD	35
Participants	35
Experimental variables	36
Experimental design and tasks.....	37
Apparatus and driving environment	40
Procedure	43
CHAPTER IV RESULTS AND ANALYSIS	44
CHAPTER V DISCUSSION.....	52
Results of the ANOVA and graphical analyses.....	52
Results of the Fourier analysis.....	54
Results of the linear mixed effects (LME) model	54
CHAPTER VI CONCLUSION	56
APPENDIX A – ANECDOTE OF I-80 ACCIDENT	59
APPENDIX B – ORDER OF TEST RUNS	60
APPENDIX C – SUPPLEMENTARY DATA ANALYSIS	61

Test runs with lead vehicle	62
Test runs without lead vehicle	64
APPENDIX D – ANALYSIS OF INDIVIDUAL SPEED PROFILES	67
APPENDIX E – COMMENTARY	70
Results of analysis of lane-keeping behavior	70
REFERENCES	72

LIST OF TABLES

Table 1 – Interventions concerning speed regulation	9
Table 2 – Interventions concerning path regulation	12
Table 3 – Interventions concerning illumination	14
Table 4 – General regulatory interventions	16
Table 5 – Parameters for determining edge rate	32
Table 6 - Participant demographics	36
Table 7 - Latin Squares to determine the order of work zone type.....	40
Table 8 - Linear mixed effects model summary table	51
Table 9 - Anova of linear mixed effects model	51
Table B1 – Order of administered test runs	60
Table C1 – ANOVA of means speed for test runs with lead vehicle	61
Table C2 – ANOVA of means speed for test runs without lead vehicle	61

LIST OF FIGURES

Figure 1 – Apparent motion of lit beacons	24
Figure 2 – Number of beacons in a wave and its wave length	27
Figure 3 – Edge rate isosurfaces under Case A	29
Figure 4 – Edge rate isosurfaces under Case B.....	30
Figure 5 – Edge rates at $V_2 \approx 55$ mph.....	31
Figure 6 – Test run design	39
Figure 7 - Driving simulator apparatus.....	41
Figure 8 - View from driver's perspective.....	41
Figure 9 - Data analysis scheme	45
Figure 10 - Fourier analysis of first set of measures.....	48
Figure 11 - Fourier analysis of repeated measure	49
Figure C1 – Check for normality of speed data.....	62
Figure C2 – Scatter plot of mean speeds within work zones in test runs with lead vehicles	63
Figure C3 – Box plot of mean speeds within work zones in test runs with lead vehicles	63
Figure C4 – Mean speeds within work zones in test runs without lead vehicles.....	65
Figure C5 – Ordered averages of mean speeds within work zones (Test runs without lead vehicle).....	66
Figure D1 – Speed profile of Participant 15-M in test runs without lead vehicle	68
Figure D2 - Speed profile of Participant 15-M in test runs with lead vehicle	69
Figure E1 - Lane position versus distance along test drive	70

INTRODUCTION

The extensive network of highways in the United States included more than 8.4 million lane miles of paved roads in the year 2005 (Transportation Statistics Annual Report, 2007). This network continues to expand and requires constant maintenance. An area of a highway with construction, maintenance, or utility work activities is known as a work zone. Work zones can cause traffic congestion and pose a significant threat to both workers and motorists. In 2006, 1,010 fatalities and over 40,000 injuries occurred within designated work zones (The Nation Work Zone Information Clearinghouse^a). The Federal Highway Administration's (FHWA) Office of Safety reports that 835 fatalities occurred around work zones in the year 2007 and over 4 out of every 5 fatalities were motorists (US DOT – FHWA, 2009). Work zone crashes also include a multitude of rear-end collisions caused due to sudden braking incidences (Ullman et al., 2008b). In their analysis of work zone crashes, Ullman et al. assert that crash risks within a work zone increased by 66% and 61% for day and nighttime, respectively, relative to the risk of crashes on open roadways. The scope of the problem is fairly large, and the occupational hazards of constructing and maintaining roadways are evidently exacerbated by speeding motorists.

A report by the U.S. Department of Transportation (US DOT), National Highway Traffic Safety Administration (NHTSA) states that 13,040 fatalities, nearly one third of all motor vehicle traffic fatalities in the U.S. in the year 2007, were due to speeding-related crashes (US DOT – NHTSA, 2009). The same report provides statistics illustrating that approximately 13,000 speeding-related fatalities have occurred each year between 2002 and 2007. Speeding is clearly a factor that contributes to traffic accidents and fatalities, and in a report to Congress in 2008, NHTSA cited the top three critical factors in roadway crashes as “inadequate surveillance” (20.3%), “internal distraction” (10.7%), and “[driving] too fast for conditions” (8.4%) from their analysis of

approximately 5,100 crashes (US DOT – NHTSA, 2008). Statistics explicitly correlating work zones and speeding are not available. However, the case provided in Appendix A provides evidence, and one can conjecture from the above arguments of speeding and work zone incidents that a means for preventing speeding-related fatalities in work zones, particularly in low-visibility conditions, is necessary. Rear-end collisions were also surmised as significant traffic incidents in the report by Ullman et al. (2008b). Abrupt differential in the speed of the lead and following vehicles is clearly a major factor contributing to rear-end collisions.

Cost-effective measures that help moderate driving speeds as well as alert motorists of special roadway conditions, particularly under low-visibility conditions, are needed to make highways safer and more manageable. With this general aim, research investigating countermeasures to speeding was conducted. The specific aims of this research were as follows. The first aim was to conduct a thorough review of the literature on work zone interventions and identify gaps in research; this study is provided in the background section. From the literature review a number of avenues for research were identified; of these, “perceptual countermeasures” appeared to be the most promising. Perceptual countermeasures are means of regulating driving speeds by manipulating the visual scene to help motorists moderate their driving speed without a conscious decision to do so. Next, the thesis focuses on identifying a means of implementing perceptual countermeasures in low-visibility conditions using synchronized, flashing warning lights or beacons to create a perception of waves of lit beacons moving toward the motorist. The procedure describes limiting conditions under which specific edge rates can be achieved as a function of the distance between successive beacons, time delay between successively lit beacons, and the drivers’ speed.

A driving-simulator-based study was devised to test whether moving waves of lit beacons created to achieve a particular edge rate were significantly effective in moderating speeding compared to two different conditions of lit beacons. The outcomes

of the study did not yield a definitive conclusion in evaluating the efficacy of synchronized warning lights as a perceptual countermeasure to moderate speeding (reduce mean speeds to match with posted speed limits).

The main contributions of this thesis include:

1. Elucidating theoretic foundations of perceptual countermeasures for speeding in work zones using flashing beacons
2. Determining constraints and parameters that govern the use of synchronized flashing beacons and their range of possible values
3. Determining a method to calculate edge rates
4. Examining the effect of the devised countermeasure on speeding behavior (mean speeds) within the work zone and possible cause of rear-end collisions
5. Use of Fourier analysis to showcase an analysis technique suitable for driving research data
6. Identification of possible drawbacks of using flashing lights as a warning or speeding countermeasure

CHAPTER I BACKGROUND

Work zone safety issues

Innovations in work zone safety are needed to reduce the number of incidences and fatalities. These concerns parallel the goals of the Midwestern Smart Work Zone Development Initiative (SWZDI), which provided the impetus and funding for reviewing existing interventions and researching ways to improve work zone safety through a pilot study.

A number of interventions have been put into effect to regulate the path and speed of traffic in work zones. Typical interventions include increasing or decreasing buffer zones, taper area, transition during lane drops, change of speed limit, distance of sign boards, rumble strips or speed humps, flaggers and use of changeable message signs (CMS) (US DOT – FHWA, 2007; Li and Bai, 2008). Empirical studies have examined flaggers, photo enforcement, CMS and speed humps (see Tables 1 to 4 for a summary). Other interventions such as length of taper, sign placement, lighting devices, etc., are usually implemented through experience and “engineering judgment” (US DOT – FHWA, 2007 Sections 2C.02 and 6C.01, Bai and Li, 2009). Testing and validating work zone interventions is crucial because, if poorly implemented, they can potentially degrade traffic flow and safety. The interventions implemented do not particularly target a type of incident.

While there was a 17% decrease compared to those in 2006, more than 1,000 work zone fatalities occurred each year between 2002 and 2006 (National Work Zone Safety Information Clearinghouse). Additionally, the total number of injuries due to motor vehicle crashes in work zones rose from 36,000 in 1996 to 41,000 in 2003 (US DOT – FHWA, 2008), and over 40,000 injures occurred in the year 2007 (US DOT – FHWA, 2009). While damage to property and equipment in a work-zone-related accident are significant, the focus of this thesis is on the hazard to humans within a work zone.

From this perspective, the accidents were categorized into two categories (Mohan and Zech, 2005):

1. Motorist-related accidents – Work zone accidents where incursion into the work zone or collision around the work zone by motorists with a worker and/or work zone feature results in injury or fatality of workers and/or motorists.
2. Occupational accidents – Work zone accidents where a worker suffers injury or fatality due to equipment, vehicle or environmental factors within the active work area.

The fact that 4 out of every 5 fatalities reported around work zones involves a motorist (US DOT – FHWA, 2009) justifies emphasis on regulating motorists' driving behavior in work zones. Though useful and necessary, the variability in motorists' driving behavior is difficult to counteract through planning, education and training. Such measures can be more tightly implemented with work zone workers to mitigate occupational accidents.

Antonucci et al. (2005) provide recommendations on reducing collisions within work zones. The report explains that greater change in velocity during an impact such as hitting a barricade (frontal collision) results in greater crash severity. It also argues that aggressive driving behavior (sudden braking, rapid acceleration and forced lane changing) is a key contributor to rear-end collision where sudden braking causes the following vehicle to collide into the braking vehicle. While the report observed fewer fatalities in rear-end collisions, the numbers of such accidents were found to be much greater in number than frontal accidents. It does not, however, provide specific data enumerating the number and types of accidents.

Hence, the focus of this thesis is narrowed down to the first category of work zone crashes – incidents involving motorists – with an emphasis on moderating mean speed and variation in speed. This moderation would be characterized by

1. Lowered mean speeds within work zones reaching closer to the posted speed limit
2. Reduced incidences of sudden increase and decrease in speed
3. Slower changes in speed with lesser magnitude of change

The following section reviews measures currently in use to regulate motorists' driving behavior in work zones. Notable findings among selected empirical studies are delineated to identify those that can successfully match the above expectations.

Work zones and work zone interventions

The Manual on Uniform Traffic Control Devices (MUTCD) (US DOT – FHWA, 2007) by the Federal Highway Administration (FHWA) provides guidelines and specifications to various transportation and highway agencies. Section 6 of the MUTCD describes temporary traffic control (TTC) measures concerning work zones and traffic incidents. A highway work zone extends from the first sign board or vehicle with strobe lights to the last sign board marking the end of the work zone.

How motorists drive within this specific enclosure and means of affecting their behavior to ensure safety and optimize traffic flow with respect to the expectations mentioned previously are reviewed. In general, traffic is warned of special roadway conditions using sign boards, i.e., they are given advance warnings and directed out of the path of the work zone. TTC devices such as cones, drums and barriers are set up to demarcate the work zone and guide traffic around it. Tables 1 through 4 enumerate typical work zone interventions currently in use. The tables compare the intended function of different interventions. These functions are grouped into four categories – speed regulation, path diversion, work zone illumination and general regulatory measures. In each of these tables, interventions that can be studied in driving simulators and that have received insufficient attention by researchers are highlighted in bold text.

Speed regulation

The objective of these measures is to inform motorists of the posted speed limit and/or influence the choice of driving speed. The approach can be direct or indirect. Here, distinction between the two is based on the level of conscious effort the intervention elicits from motorists in changing their driving behavior.

Under direct countermeasures, changeable message signs (CMS), also known as variable message signs (VMS), see popular use. These are electronic boards with a grid of light bulbs or light-emitting diodes that can display a variety of symbolic and textual messages. These have the notable advantage of being more visible during poor lighting conditions and can be made to flash to attract more attention. Like static message signs, their primary objective is to warn motorists of impending roadway conditions and provide speed advisory. A CMS-related technique is the use of radar that gauges an oncoming vehicle's speed and displays a warning message on a CMS, such as "Your speed is XX mph – Slow down now" if the vehicle is traveling notably above the posted speed limit. This technique has been studied extensively (see Table 1 for summary) and has been shown to have a significant effect on driving behavior. While CMS are typically portable and can be transported to a temporary work zone, they are more expensive than static signs. Another CMS-related technique is variable speed limit (VSL). Depending on weather, daytime/nighttime and traffic conditions ascertained by operators or sensors, different networked CMS upstream from the work zone are activated to display a particular speed limit. This system has been reported to have a statistically significant effect on speeding behavior (Riffkin et al., 2008; Michigan DOT, 2003).

Another direct way of enforcing speed regulation is the use of temporary rumble strips. Empirical studies that have examined the use of rumble strip (Meyer, 2003; Meyer, 2005; Noel et al., 1989) observed mixed outcomes on regulating speeding behavior and noted that constructing continuous sections of rumble strips is cost prohibitive. Other direct and more effective means include the use of uniformed law enforcement officials

and/or vehicles and use of photo-enforcement of speed limits. However, these methods are costly and can add to the financial burden of constructing and maintaining roadways.

An alternative and indirect approach is the use of perceptual countermeasures, which is argued to be more cost effective than the use of additional enforcement or rumble strips. Perceptual countermeasures are non-obtrusive means of reducing driving speeds by manipulating the visual environment to induce a perception of higher driving speeds. These typically involve the use of pavement markings such as chevrons or horizontal bars that transverse the direction of traffic. Recent empirical studies within the U.S. (Katz, 2004; Voigt and Kuchangi, 2008) with perceptual countermeasures using pavement markings have shown effectiveness in regulating speed but have recommended that further investigations into their usability be made. These studies also allude to a “calming effect,” indicated by lesser variation in driving speeds. Another method demonstrated by Vercurysen et al. (1995) in a simulator-based study was a perceptual countermeasure using synchronously lit flashing beacons that had statistically significant effect on regulating driving speeds within the work zone.

Path diversion

The objective of these measures is to demarcate the work zone and prevent incursions into the work area by motorists. Closing lanes or an entire road section naturally lowers traffic throughput and increases travel time. This has adverse effects on people’s sentiments as well as economic repercussions for individuals and businesses (US DOT – FHWA, 2008). This measure is, however, necessary so that work can be carried out and workers can be safe from oncoming traffic. Typically, when lanes are closed, permanent pavement markings and signage are replaced or modified with temporary ones. Ullman et al. (2008a) noted that considerable care needs to be taken so that motorists can clearly comprehend new markings and signage to negotiate safely through the work zone.

Table 1 – Interventions concerning speed regulation

Intervention	Description	Empirical Studies
Changeable message signs (CMS)	Message boards with light bulbs or light-emitting diodes (LED) post warning messages such as lane closures, speed limit, fines for speeding, etc. Also known as variable message signs (VMS).	Brewer et al. (2006), Benekohal et al. (1992)
Vehicle-triggered CMS	Speeding vehicle triggers a CMS equipped with radar that shows specific warnings such as “You are speeding” or “Slow down now” or current speed against posted speed limit. The CMS may be placed on a mobile trailer.	Pesti and McCoy (2007), Wang et al. (2007), Brewer et al. (2006), Fontaine et al. (2000), Garber and Patel (1994, 1995)
Variable Speed limit (VSL)	The normal posted maximum speed limit is typically reduced by 10 mph around work zones. Based on work zone conditions, posted speed limits are changed dynamically using a CMS.	Riffkin et al., (2008), Michigan DOT (2003)
Presence of uniformed law enforcement officials and/or police vehicle	Uniformed law enforcement officials provide assistance in regulating traffic, and their presence heightens motorists’ alertness.	Medina et al. (2009), Kamyab et al. (2003), Noel et al. (1987)
Photo-enforcement	An automated system that takes a photo of a vehicle that violates traffic rules such as speeding, running through red lights or stop signs, etc.	Medina, Juan C. et al. (2009)
Flaggers	Highway workers by the work zone who direct traffic using hand-signaling devices such as paddles, lights and flags.	Garber and Woo (1990), Noel et al. (1987)
Rumble strips	Temporary rumble strips can be set up in critical zones to lower speed.	Meyer, E. (2003; 2005), Fontaine et al. (2000), Noel et al. (1989)
Perceptual countermeasures	Pavement markings used to give a perception of driving at higher speeds while approaching a critical area, which causes motorists to decelerate	Katz (2004), Voigt and Kuchangi, (2008)
	Synchronized flashing warning lights used to generate a wave of lights moving toward or away from the driver, generating a perception of driving at a higher or lower speed.	Vercuryssen et al. (1995)
Radar drone	A drone that emits a radio frequency that triggers commercially available radar detectors, giving motorists the impression that police enforcement is in effect in the work zone.	Fontaine et al. (2000)

Note: Interventions that can be studied in driving simulators and/or that have received insufficient attention by researchers are highlighted in bold text.

A related concern is pavement marking design. Research in this area has primarily focused on improving their visibility (Ullman et al., 2008) so that appropriate open lanes are utilized by motorists. A few studies have also examined their influence on speeding behavior (Schnell, 2007; Lessner, 2005) and have reported nominal or not statistically significant effects.

Different strategies in implementing path diversions, such as dynamically changing the distance before the work zone where traffic moving toward closed lanes merges into open lanes, can improve traffic manageability in work zones. This system is called the dynamic late merge system (DLMS). Studies by the Minnesota DOT (2004) and Scriba and Luttrell (2004) have argued their effectiveness in improving traffic manageability, while studies like that carried out by Beacher et al. (2004) have found their effectiveness to be limited. Related to the “allowance” in time or distance given to motorists to merge into open lanes is the design of taper sections, which has not been studied rigorously. Taper design is typically implemented by using the MUTCD; Section 6C.08 provides two tables for determining taper design: Table 6C-3, "Taper Length Criteria for Temporary Traffic Control Zones," and Table 6C-4, "Formulas for Determining Taper Lengths." A discussion on how these tables were devised is not provided in the MUTCD.

Positive separation of the work zones using channeling devices such as barriers is necessary to prevent incursions into the work zone. The effect of different channeling devices on motorists' behavior is an area that needs further investigation. For instance, Garber and Woo (1990) noted decreased effectiveness of different TTC devices if they were used in combination with barricades. Another concern studied by Bligh et al. (1998) is the consequence of impact with a TTC device, and safety features must be incorporated into them to minimize risk and damage to motorists.

A work zone design feature and a possible means of devising a countermeasure is the combination of TTC devices and lateral buffer distance. Lateral distance between the

traffic stream and the active work zone may affect driver behavior. Motorists may drive closer or shy away from the TTC devices and drive faster or slower depending on their perception of how permeable the arrangement of the TTC devices is and how close the work zone activities appear to be. A greater push toward research on controlling traffic in the traverse direction of the road has begun with the contention of early versus late merge strategy (see “Transition strategy” in Table 2). The end objective in the use of either strategy is to alleviate conflicts between vehicles that arise while transitioning to open lanes from ones that are about to end due to the work zone. Late merge strategy (LMS) uses signals at the merge point allowing vehicles positioned in open lanes and in closed lanes to stop and move alternately. Early merge strategy (EMS) uses greater leeway in transitioning by increasing the taper section with message boards indicating that motorists should settle into the open lane long before the last merge point. The contention of which strategy is optimal (making maximum use of lane capacity versus safety issues) remains to be solved and is worth investigating.

Considerable research concerning path regulation along the direction of the road (headway distance) is available in cruise control literature, and the study of car following behavior has contributed to the development of numerous driver models and traffic simulation models (Kim et al., 2007). Traffic safety campaigns have also advocated norms such as the “two-second rule.” However, research on car-following behavior specifically within work zones needs further investigation. Whether motorists should adopt a greater factor of safety and increase their headway is an important question that needs to be addressed.

Work zone illumination

The objective of these measures is to make work zones, approach areas and work zone elements more visible and conspicuous to drivers. Drivers can thus anticipate events

and can use appropriate judgment while driving through the work zone, particularly in nighttime and low-visibility conditions.

Table 2 – Interventions concerning path regulation

Intervention	Description	Empirical Studies
Road closures, lane closure and narrowing lanes	Traffic is diverted away from the work zone. This typically involves lane closures and/or narrowing of lanes. Entire roads may be closed if necessary.	Chitturi et al. (2008), FHWA Report No FHWA-OP-04-009 (2003)
Disambiguation between permanent and temporary signs and pavement markings	Typically permanent signs and pavement markings are removed around work zones and new temporary ones are put in. Better alignment of markings with open roadways improves drivers' ability to identify open paths.	Ullman et al. (2008a)
Design of pavement markings	Geometric design modifications to conventional pavement markings improve recognition, warn motorists and/or perceptually affect motorists' driving behavior.	Voigt and Kuchangi, (2008), Ullman et al. (2008a), Zwahlen and Schnell (2007), Lessner (2005)
Length of taper at transition and termination area	Transition area precedes the work zone where traffic moves out of the closed lanes and the termination area allows traffic to move into the normal roadway. The taper facilitates merging into common road space.	
Transition strategy	Strategy implemented for adjusting the distance before the beginning of the work zone where traffic merges in or out of a lane to accommodate lane closure.	Minnesota DOT (2004), Scriba and Luttrell (2004), Beacher et al. (2004)
Channelizing devices	Channelizing devices include cones, drums, barricades, etc. that demarcate the work zone and separate the traffic from the work area.	Fontaine et al. (2000), Bligh et al. (1998), Ross et al. (1993), Garber and Woo (1990)
Design of lateral buffer zone	Lateral distance between the traffic stream and the active work zone.	
Headway control	Advocating a particular headway or car-following behavior within the work zone.	
Shadow or pilot vehicle	A vehicle equipped with appropriate light and warning signs that trails close to mobile and constantly moving operations such as pothole repair, striping, etc.	

Note: Interventions that can be studied in driving simulators and/or that have received insufficient attention by researchers are highlighted in bold text.

NCHRP Report No. 627 by Ullman et al. (2008b) points out that the increased risk of crashes within work zones relative to open roadway during nighttime is not greater than the increased risk in daytime. The increased crash risk in daytime is largely

attributed to the fact that there is a much higher volume of traffic compared to nighttime. From this, one can intuitively discern that even with lowered traffic volume the increased crash risk associated with traveling through a work zone at nighttime is similar to that of daytime. The study also found within the NYSDOT accident data that worker-involved traffic crashes (not necessarily meaning that a worker was struck by a vehicle) in nighttime work zones were significantly more severe than those that occurred in daytime. Concurrently, Section 6G.20 of the MUTCD asserts that “because traffic volumes are lower and congestion is minimized, [driving] speeds are often higher at night. [And], the incidence of impaired (alcohol or drugs), fatigued, or drowsy drivers might be higher at night.” The combined effect of higher driving speeds and lower visibilities at night would be expected to increase the risk of traffic incidents. Helping motorists use appropriate discretion to safely navigate through a work zone at nighttime requires an emphasis on improving work zone visibility.

To this effect, notable research on illumination, reflectivity and fluorescence by Zwahlen and Schnell (1997) provides recommendations on improving pavement marking reflectivity, visibility of objects under illumination by vehicle headlights, general illumination of roadway under static overhead lighting, visibility of different colored objects (e.g., roadway signs) and legibility of symbols and text on roadway signs. Table 1 provides additional sources of literature among which the general consensus is that

1. Flashing lights increase conspicuity, but their use must be restricted to vital areas and to communicate specific danger such as the possibility of hitting a human.
2. White, amber and especially yellow-green color are most distinctly visible to the human eye.
3. Retroreflective material (tape and sheeting) improves conspicuity and has the added benefit of being less costly because it enhances luminance without requiring a power source for generating illumination like strobes

or beacons. Hence, retroreflective material is very useful in making worker apparel, TTC devices and roadway signs and in highlighting the edges of construction vehicles and equipment.

Although research on adequacy of work zone illumination typically requires field experiments and advanced photometry equipment, one can use a model-based approach and objectively quantify work zone conspicuity given different illumination conditions and luminance countermeasures as proposed by Aktan et al. (2006) and Barton et al. (2002). These computational tools promise a valid means to evaluate changes implemented in work zones that are aimed at improving visibility and conspicuity. Additionally, improved driving simulators with advanced rendering capabilities can be used to study various lighting conditions within work zones.

Table 3 – Interventions concerning illumination

Intervention	Description	Empirical Studies
General work zone illumination	General work zone conspicuity during day and nighttime	Ullman et al. (2008b), Aktan et al. (2006), Barton et al. (2002)
Steady burn or flashing warning lights or beacons	Warning lights or beacons draw additional attention to critical areas, warning signs and channelizing devices. They are used under steady burn or flashing mode.	Gibbons et al. (2008), Finley et. al (2001)
Retroreflectivity and fluorescence	Materials and colors that make road signs, equipment, vehicles, TTC devices and clothing worn by highway workers highly reflective and/or contrasting from the surroundings, hence making them more conspicuous.	Fontaine et al. (2000), Zwahlen and Schnell (1997)

Note: Interventions that can be studied in driving simulators and/or that have received insufficient attention by researchers are highlighted in bold text.

General regulatory measures

The objective of these measures is to provide systemic regulations and guidance to improve overall work zone management and safety. These measures can reach beyond

the active work zone and aim to affect society in general to instill a safety culture among drivers. A number of states have adopted a public awareness and education campaign to achieve this (The National Work Zone Safety Information Clearinghouse^b). Whether these campaigns must have a “shock and awe” or “sympathetic” or some other component and their possible efficacy is discussed by Fylan et al. (2006), who address theoretical human factors issues of speed mitigation in the United Kingdom.

Careful and adequate planning of work zones and their duration of activity is necessary. Guidelines such as NCHRP Report Nos. 546 and 500 recommend the need to decrease motorists’ exposure to work zones by asserting a time to completion component apart from financial cost in selecting contractors during bidding processes for the work. Apart from these, the MUTCD provides great contributions in asserting standardization of work zone regulation. A number of differences exist in the type of technology and enforcement used across states, which can be largely attributed to differences in funds available. However, maintaining consistency among work zone elements is necessary to enhance their recognition among motorists, especially truck drivers, who typically commute across state lines. For instance, the use of information technology systems (ITS) and fines are more vigorous in some states than in others. Huebschman et al. (2003) provide a detailed discussion of ITS used in various states and in selected European countries to evaluate their efficacy. They state that more carefully planned use of ITS is needed to derive benefits that offset their steeper costs. Another important concern is the placement of warning signs, their legibility and comprehension. Benekohal et al. (1995) found through a survey that truck drivers preferred that warning signs be placed 3 to 5 miles in advance of the work zone. The distance of the signage from the work zone as a control variable has not been examined rigorously even though implementation of techniques like VSL requires networked CMS that need to be placed at various distances upstream from the work zone. Various studies on legibility and comprehension (Ullman et al., 2005; Dudek and Ullman, 2002; Durkop and Dudek, 2001) assert that static (not

flashing) short messages in bold characters are legible and more quickly recognized at greater distances under different lighting conditions. This can afford better comprehension. Also, the use of symbols and graphics may improve comprehension, particularly among non-native English speakers (Wang et al., 2007).

Table 4 – General regulatory interventions

Intervention	Description	Empirical Studies
Public awareness and education	Promotional campaigns aimed at building a safety culture among commuters.	The National Work Zone Safety Information Clearinghouse Fylan et al. (2006)
Work zone planning and worker training	Guidelines for planning project duration and traffic control plans as well as worker training provide systemic regulation of safety and traffic throughput around work zones.	Washington et al. (2006), Antonucci et al. (2005)
Information Technology	Use of sensors, relays, CMS, radio stations, etc. to inform motorists of impending roadway conditions.	Huebschman et al. (2003)
Fines	Fine for moving vehicle violations within work zones typically double, and hitting a worker also entails imprisonment.	Huebschman et al. (2003)
Advanced warnings	Static sign boards or CMS inform motorists of what to expect ahead in distance and/or time. The distance of the signage from the work zone and the date/time mentioned on the signage is a control variable.	Benekohal et al. (1995), Huebschman et al. (2003)
Verbiage and symbolism used on sign boards and their design	The wording and symbols used on signboards must convey the appropriate message. The sign boards must be visible and legible in a variety of lighting and weather conditions.	Wang et al. (2007), Ullman et al. (2005), Dudek and Ullman (2002), Durkop and Dudek (2001), US DOT - FHWA (1996)

Note: Interventions that can be studied in driving simulators and/or that have received insufficient attention by researchers are highlighted in bold text.

Gaps in empirical research

Extensive data is available within the work zone literature on decreasing mean speeds, design of signs, CMS, vehicle-triggered CMS, photo enforcement, pavement

marking visibility and use of retroreflectivity and fluorescence. Fitzsimmons et al. (2009), Li and Bai (2008), Brewer et al. (2006), Antonucci et al. (2005), Huebscman et al. (2003), Fontaine et al. (2000) and Benekohal et al. (1992) are recommended readings for reviews of work zone interventions. Notable areas that need further investigation are:

- Managing variability in driving speeds
- Car-following behavior within work zones
- Taper design and its effect on traffic regulation
- Effect of distance of signs from the work zone on driving behavior and driver attentiveness
- Effect of different TTC devices and their combinations on driving behavior
- Effect of lateral buffer distance
- Perceptual countermeasures

Areas that have been investigated but come up with mixed results or have cost-related concerns are the use of rumble strips, flashing lights, conducting work zone activities during nighttime versus daytime, late merge versus early merge, dynamic late merge, additional police enforcement and effectiveness of fines. A greater push toward empirical studies on safety and traffic manageability using these interventions is needed.

The literature survey indicates that research in the area of perceptual countermeasures is gaining prominence. Compared to other gaps identified in the literature survey, perceptual countermeasures better fulfill the requirements of devising a cost-effective measure that helps moderate driving speeds and, potentially, headways. They can also help alert motorists of special roadway conditions, particularly under low-visibility conditions, if implemented with flashing beacons. Driving and visual perception are invariably interconnected. Perceptual countermeasures offer a novel means of exploiting this relationship and allowing the motorist to choose a suitable driving speed without direct assertion to moderate speeds from authorities. Its most promising virtue is

in its ability to affect the driver at a perceptual level to moderate attitudes rather than enforcing a penalty such as encountering discomfort over speed humps, which is less likely to affect one's driving attitude. This theoretically inclined question of affecting driving attitudes versus situated speed mitigation is another key reason for concentrating on perceptual countermeasures. The following section reviews literature on perceptual countermeasures.

Perceptual countermeasures

Perceptual countermeasures are non-obtrusive means of reducing driving speeds by manipulating the visual environment to induce a perception of higher driving speeds. The driver thus achieves a notion of driving at a “comfortable and safe driving speed” at a lower vehicular speed. The technique typically involves use of pavement markings such as chevrons, traverse lines, herringbone patterns, etc. painted perpendicular to the path of traffic. In the late 1960s the technique was studied and promoted by Denton (1971 and 1980). In Denton's study, traverse lines marked at exponentially decreasing distances at a busy roundabout in Great Britain produced notable reductions in the average speed of drivers. More recently these measures have been put into use on roadways in other countries such as Japan, Canada, South Africa, Israel, and Australia (Griffin and Reinhardt, 1996). They have been studied extensively in driving simulators by Godley (1999) in New South Wales, Australia. In the United States, studies have been carried out with chevron pavement markings in Kansas (Meyer, 2000), Virginia (Katz, 2006), Wisconsin (Darkopoulos and Vergou, 2003), and Texas (Voigt and Kuchangi, 2008) on freeways with evidence of significant speed reduction and of long-term speed reductions. A report by MassSAFE at the University of Massachusetts reviewed implementation of perceptual countermeasures in the U.S. and asserts that “as a simple and effective device, passive speed control measures can be a valuable tool for improving traffic safety.”

A more recent simulator-based study conducted by Manser and Hancock (2007) involved painting tunnel walls with varying widths of black and white vertical stripes. Their findings suggest that “drivers exposed to a visual pattern that gradually decreased in width responded by gradually decreasing vehicle speed throughout the tunnel.” Equally spaced thin black stripes on a white wall did not produce notable effects, and thin to wide black stripes on a white wall seemed to produce gradually increasing speeds.

While perceptual countermeasures with pavement markings achieve most of the requirements discussed earlier, their particular shortcoming has been their lesser degree of effectiveness during nighttime and low-visibility conditions (Griffin and Reinhardt, 1996; Katz, 2006). Additionally, pavement markings are not well suited to long-term work zones where they would become worn out and dirty and require refurbishing. Finley et al. (2001) conducted a study using flashing warning lights placed on a test track and on a roadway in Texas that addressed the issue of visibility. Their main purpose, however, was to study lane-merging behavior of motorists. In the study, the tapered approach to a work zone termed as a transition area had drums with warning lights’ flashes synchronized to produce a wavelike motion. This is also known as the Phi effect (Steinman et al., 2000). They found that when the countermeasure was implemented at a particular site in Texas, motorists, particularly truck drivers, chose to merge out of the closed lane further upstream. This behavior improved traffic flow, and the authors argue that it could enhance safety. The authors also assert that since motorists did not exhibit erratic driving behavior, the flashing lights did not appear to confuse or surprise the motorists. They did, however, raise concerns about the possibility of triggering epileptic seizures due to flashing lights. Photosensitive epilepsy is a form of epilepsy in which the patient goes into a seizure triggered by visual stimuli such as flickering or flashing lights. “Flashing lights most likely to trigger seizures are between the frequency of 5 to 30 flashes per second” (epilepsyfoundation.org). Additionally, Section 508 of the U.S. Rehabilitation Act of 1973 directs that web and software content shall “not use flashing

or blinking text, objects, or other elements having a flash or blink frequency greater than 2 Hz and lower than 55 Hz.” Keeping in mind these limitations, synchronized warning lights can prove effective in moderating driving speeds even in low-visibility conditions.

While these studies show substantial evidence that correlates perceptual countermeasures and reduction in driving speed as well as crash rate, their aim was not to evaluate the theoretical basis of how such an intervention can work to achieve these effects. Also, it is argued that similar to speed signs, the effect of pavement markings such as chevrons or traverse bars is to merely warn drivers to slow down rather than to induce a perception of driving at higher speeds (Griffin and Reinhardt, 1996; Godley et al., 1999). These are two important issues examined in this thesis.

Underlying theory of perceptual countermeasures

Theoretically, pavement markings like traverse bars should increase the number of edges or discontinuities crossing an observer’s field of view per unit of time, thereby increasing edge rate, which is dependent on surface texture and is a constituent of the optical flow field (Gibson, 1950). The other constituent of optical flow field is global flow rate, which is defined as the observer’s ground speed divided by the observer’s altitude (Larish and Flach, 1990). Global flow rate depends on the observer’s eye level above ground and is independent of surface textures. While correlation between eye-height (global flow rate) and driving speed is significant and observed to be linear (Rudin-Brown, 2006), research by Owens (1982) and Larish and Flach (1990) demonstrated that edge rate plays a more prominent role in perception of self-motion and speed than global flow rate. Hence, this study focuses on a method to manipulate the edge rate in a perceptual countermeasure with the specific intent of improving traffic safety around work zones.

Larish and Flach (1990) conducted a study similar to those conducted by Owen (1982) to compare and contrast global flow rate and edge rate. In the first experiment of

the study, they varied the edge rate (values 0.05, 0.1, 0.3, 0.6 and 1.0 edges per second) along with the global flow rate (values 0.5, 1, 2, 4 and 8 eye heights per second) using a factorial design to study the effect on perceived speed measured through subjective ratings. Their paper as well as Owen's (1982) do not clearly indicate how and why particular values of edge rate were chosen. However, Larish and Flach did demonstrate that, for any particular global flow rate, perception of speed was notably higher for edge rates of 0.6 and 1.0 edge per second. This was further evident in a subsequent experiment presented in the same paper that included an edge rate of 1.5 edges per second. This thesis therefore advocates the use of 1.0 to 1.5 edges per second in devising perceptual countermeasures. Another important inference from their study was that edge rate information is available from generalized patterns of discontinuities rather than simple salience of edges. Since edge rate is dependent on the texture of the visual field, an experimental setup to manipulate it must manipulate the geometric construct of what is visible to an observer in motion. While their study provides important inferences, it does not shed light on how to achieve a particular edge rate while devising perceptual countermeasures.

An approach to understanding perceptual countermeasures and the use of flashing warning lights to manipulate edge rate was demonstrated using a driving simulator by Vercurysen et al. (1995). Their study involved using warning lights placed on drums lit in a sequential manner to generate an illusion of a moving wave of lit warning lights. Their supposition was that motorists subconsciously synchronize their behavior with the movement of the lights. Their findings supported their hypotheses that drivers would slow down when the wave of lights was moving toward them and that drivers would speed up or chase the wave when it was moving away from them. The authors observed that stationary lights had little or no effect on driving behavior. This technique was not investigated on a test track or in the field, and the authors did not provide a concrete

discussion on how the technique works. However, they too did not provide an adequate explanation about the process of deciding upon and achieving a particular edge rate.

The use of perceptual countermeasures for traffic regulation has been gaining precedence, and field studies are active across the world and also in parts of the United States. Within the available literature there has been a major focus on observational field studies aimed at finding a correlation between particular perceptual countermeasures such as pavement markings and drivers' mean speed reduction usually between a single data collection sites before and after the work zone. These studies do show a strong correlation between the two. However, these studies and even experimental studies like the ones by Manser and Hancock (2007) and Vercurysen et al. (1995) have not identified design parameters for manipulating edge rates. The following sections identify and describe parameters that can be experimentally controlled in a simulated environment to devise a perceptual countermeasure with synchronized warning lights. The terms *warning lights* and *beacons* are used interchangeably in the following sections.

In equations derived by Owen (1982), patterns that looked like agricultural fields seen from a moving aerial vantage point were used. The patterns were displayed on a computer screen. Edge rate increased or decreased strictly as a function of a "checkered" pattern's motion with respect to the ground since the observers were motionless with respect to the ground. However, in the case of synchronized warning lights, the challenge is in consolidating relative motion of both the wave of moving lights and the observer with respect to the ground. Edge rate in the case of synchronized warning lights was taken as a function of relative motion of the observer with respect to the wave of lights. Thus, the edge rate (E) was defined as a function of distance between the warning lights (x), delay between lighting up of successive warning lights (t) and the driver's velocity (V_2) with respect to the wave of lights.

- i. Apparent motion and velocity of waves of lit warning lights (V_1), which is dependent on:

- a. Flash rate of warning lights (**f**)
 - b. Delay between lighting up of successive warning lights (**t**)
 - c. Distance between the warning lights (**x**)
- ii. Observer's velocity (**V₂**)

These parameters are bound by practical limitations and by federal regulations on traffic management. The above parameter and the conditions governing them are discussed in the following sections and summarized in Table 5 at the end of the discussion.

Determining valid values of flash rate – f

The flash rate must be kept below 2 Hz to prevent the flashing lights from triggering epileptic seizures. Additionally, the MUTCD specifies under *Section 4K.01* that flashing warning lights or beacons must have a flash rate of 50 to 60 cycles per minute. This implies that a rate of 0.8333 to 1 cycles per second or 1.2 to 1 seconds per cycle is applicable. The beacons' on and off durations constitute a cycle and can be any fraction that adds up to a value between the 1.2 and 1 second interval. For simplicity the on and off durations may be kept equal. For instance, if the flash rate is set as 1 second per cycle, the on and off durations would be 500 ms each.

Apparent motion of lit beacons

With respect to the ground, velocity of the waves depends on the distance between successive beacons and the delay between successive lighting of beacons. If the delay is **t** seconds and distance between two beacons is **x** meters, a lit beacon would “move” at the rate:

$$v = x / t \text{ meters/second} \quad \dots (1)$$

Determining valid values of distance – x

Section 6C.08 (also, section 6F.58) of FHWA – MUTCD specifies that the spacing between channeling devices should not exceed a distance in meters (feet) of 0.2 times the speed limit in km/h (1.0 times the speed limit in mph) at the tapering section and a distance in meters (feet) of 0.4 times the speed limit in km/h (2.0 times the speed limit in mph) at the tangent section, also called the transition area.

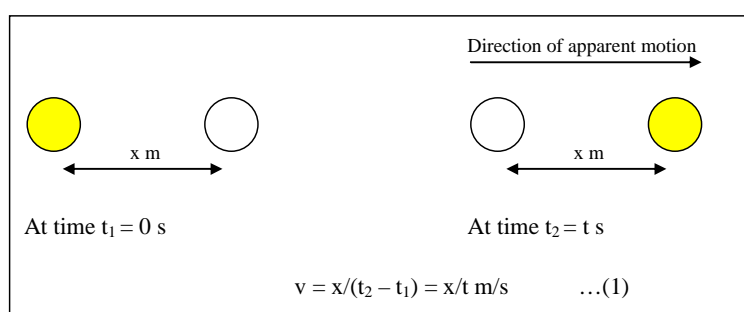

Figure 1 – Apparent motion of lit beacons

The design of the taper is determined by Tables 6C-3 and 6C-4 of FHWA – MUTCD. The first table distinguishes types of tapers based on their use, and the second table prescribes taper design as a function of posted speed limit.

On a typical four-lane highway with a median in Iowa, the posted speed limit is 105 km/h (65 mph). *Section 6C.01* of the FHWA – MUTCD directs that “TTC plan should be designed so that vehicles can reasonably safely travel through the TTC zone with a speed limit reduction of no more than 16 km/h (10 mph).” The speed limit around a work zone should therefore be 90 km/h (55 mph). The distance x between drums (warning lights) should therefore not exceed 21 meters (55 feet) at the taper zone and 36 meters (110 feet) at the tangent section.

Determining valid values of time delay – t

Time delay (**t**) is the time interval between the lighting up of successive beacons in seconds. It can be any value less than or equal to the on duration (**f_{on}**) of the flash rate. To give a smoother transition between successively lit beacons, time delay (**t**) can be slightly less than the on duration. This also causes a group of lit beacons to appear as moving rather than a single one. A small positive value, say, **c** seconds, can be subtracted from the on duration to obtain the time delay **t**. The value of **c** and its significance in producing the perception of moving lights is a psychometric exploration for further studies.

$$\mathbf{t = f_{on} - c \text{ seconds} \quad \dots (2a)}$$

Groups of moving lit beacons can also be created by turning on a set of beacons at once instead of a single beacon after **f_{on}** seconds. In this case the factor **c** would not be required and Equation 2 could also be taken as:

$$\mathbf{t = f_{on} \text{ seconds} \quad \dots (2b)}$$

Calculating relative velocity – V_R

Consider that the waves' velocity is **V₁**, given by Equation 1, and that the observer's velocity is **V₂**, and that both move along the same line. The relative velocity **V_R** can then be defined under two cases:

1. Case A

Observer and wave of lit beacons move toward each other along the same line of motion, and the wave's direction of motion is taken as positive.

$$\mathbf{V_R = V_1 - (-V_2) = V_1 + V_2 \text{ meters/second} \quad \dots (3)}$$

2. Case B

Observer and wave of lit beacons move along the same line with the waves moving away from the driver, and the wave's direction of motion is taken as positive.

$$\mathbf{V_R} = \mathbf{V_1} - \mathbf{V_2} \text{ meters/second} \quad \dots (4)$$

For **Case A**, by substituting Equation 1 in Equation 3, we get:

$$\mathbf{V_R} = (\mathbf{x/t}) + \mathbf{V_2} \text{ meters/second} \quad \dots (5)$$

Similarly, for **Case B**:

$$\mathbf{V_R} = (\mathbf{x/t}) - \mathbf{V_2} \text{ meters/second} \quad \dots (6)$$

Calculating edge rate – E

As stated earlier, edge rate depends on the texture (discontinuities) of the visual scene. Discontinuities are generated by dimmed beacons between lit beacons. Sets of dimmed and lit beacons together constitute a wave. Let the number of beacons in a wave be \mathbf{N} . Then its wave length (\mathbf{L}) as illustrated by Figure 2 is:

$$\mathbf{L} = \mathbf{N * x} \quad \text{where, } \mathbf{N > 2} \text{ and } \mathbf{N \in \mathbb{N}} \quad \dots (7)$$

It is advocated that larger gaps between successive lit beacons be used, as it gives a more prominent impression of moving lights and does not appear to be flickering, closely spaced bright and dark bulbs (see Figure 2 on next page) that can potentially cause epileptic seizures among sensitive observers. Additionally, a generalized pattern of discontinuities provides greater information on edge rate to an observer (Larish and Flach, 1990). This generalized pattern is better achieved by lighting up sets of beacons, each after a time delay (\mathbf{t}). How many beacons ought to be in a wave is a subject for future study because excessively large gaps can cause the Pi effect to break down. The edge rate (\mathbf{E}) or number of waves (discontinuities) seen by the observer per second depends on his or her velocity with respect to the wave and is given as:

$$\mathbf{E} = \mathbf{V_R/L} = \mathbf{V_R/(N * x)} \quad \dots (8)$$

By using Equations 5 in Equation 8 for **Case A**, we get:

$$\mathbf{E_A} = (\mathbf{N * x})^{-1} * (\mathbf{x/t} + \mathbf{V_2}) = \mathbf{N^{-1} * (t^{-1} + V_2 * x^{-1})} \quad \dots (9)$$

Similarly, by using Equation 6 in Equation 8 for **Case B**, we get:

$$\mathbf{E_B} = \mathbf{N^{-1} * (t^{-1} - V_2 * x^{-1})} \quad \dots (10)$$

Possible values of E are described by the volume obtained by varying values for x , t and V_2 in Equations 9 and 10. Figures 3 and 4 illustrate this volume from multiple view points by using the bounded values determined earlier and dividing them into 35 equal increments:

1. $x \in [1, 36]$ meters
2. $t = f_{on} \in [0.1, 0.6]$ seconds
3. $V_2 \in [30, 70]$ miles/hour Or, $V_2 \in [13.41, 31.29]$ meters/second

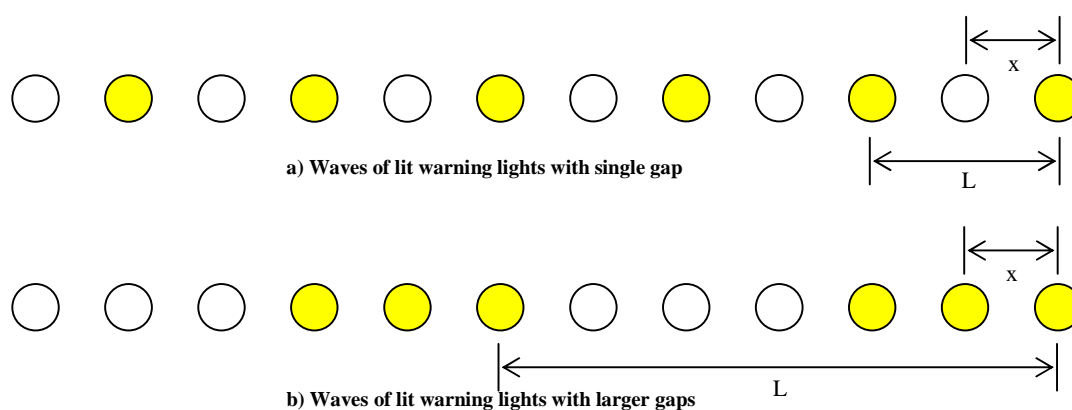

Figure 2 – Number of beacons in a wave and its wave length

Note: In Figure 2a) and 2b) N equals one and six, respectively. L – wave length, x – inter beacon distance.

In Figures 3 and 4 the minimum and maximum values of edge rate E that can be achieved under **Case A** (0.34 and 6.88 edges/s) and **Case B** (-4.94 and 1.60 edges/s), respectively, are plotted as isosurfaces with 0.25 edges/second increments from the respective minima. Graphs 1-6 in both figures are rotated viewpoints of the isosurfaces about the vertical axis through the center of the graph box.

Figure 5 illustrates possible edge rates by fixing driver speed V_2 at approximately 55 mph (24.59 m/s). Figure 5 shows that most parameter combinations in both **Case A**

and **Case B** yield an edge rate between 0 and 1.5 edges/second and in the positive directional sense, i.e., waves of lit beacons moving toward the driver.

Figures 4 and 5 expose a significant caveat in using synchronized flashing lights under **Case B**. The negative values of edge rate in those two figures for **Case B** imply that waves of lit beacons would appear to move toward the driver, which would be the inappropriate design intent under **Case B**.

The change in direction of the waves would occur because drivers would easily “overtake” the waves. The changing direction of waves could lead to a confusing situation for drivers. To successfully generate waves that appear to move away from the driver under all conditions of driving speed, the time delay must be kept at or below 0.1 s (see graph 4 in Figure 5). The exact values of t satisfying the condition $E < 0$ for all valid values of x and V_2 can be found analytically using differential equations to generate waves that move away from the driver.

Additionally, the use of larger values of inter-beacon distance x (e.g., 21 meters) and lower values of time delay t (e.g., 0.1 seconds) can produce a very rapidly moving wave of lit beacons, and it is not certain that a motorist would perceive the lights as a connected unit that produces a wave. At which combinations of inter-beacon distance x and time delay t of lit beacons still appear to be connected is an important question that would need a deeper psychometric investigation and is beyond the scope of this thesis. Parameters governing edge rate and their range of possible values are summarized in Table 5.

As seen through the above arguments, only specific flash rates and distances between successive beacons can determine possible edge rates. A top down process where a normative edge rate determined theoretically can be implemented using any flash rate and any distance between successive beacons cannot be used.

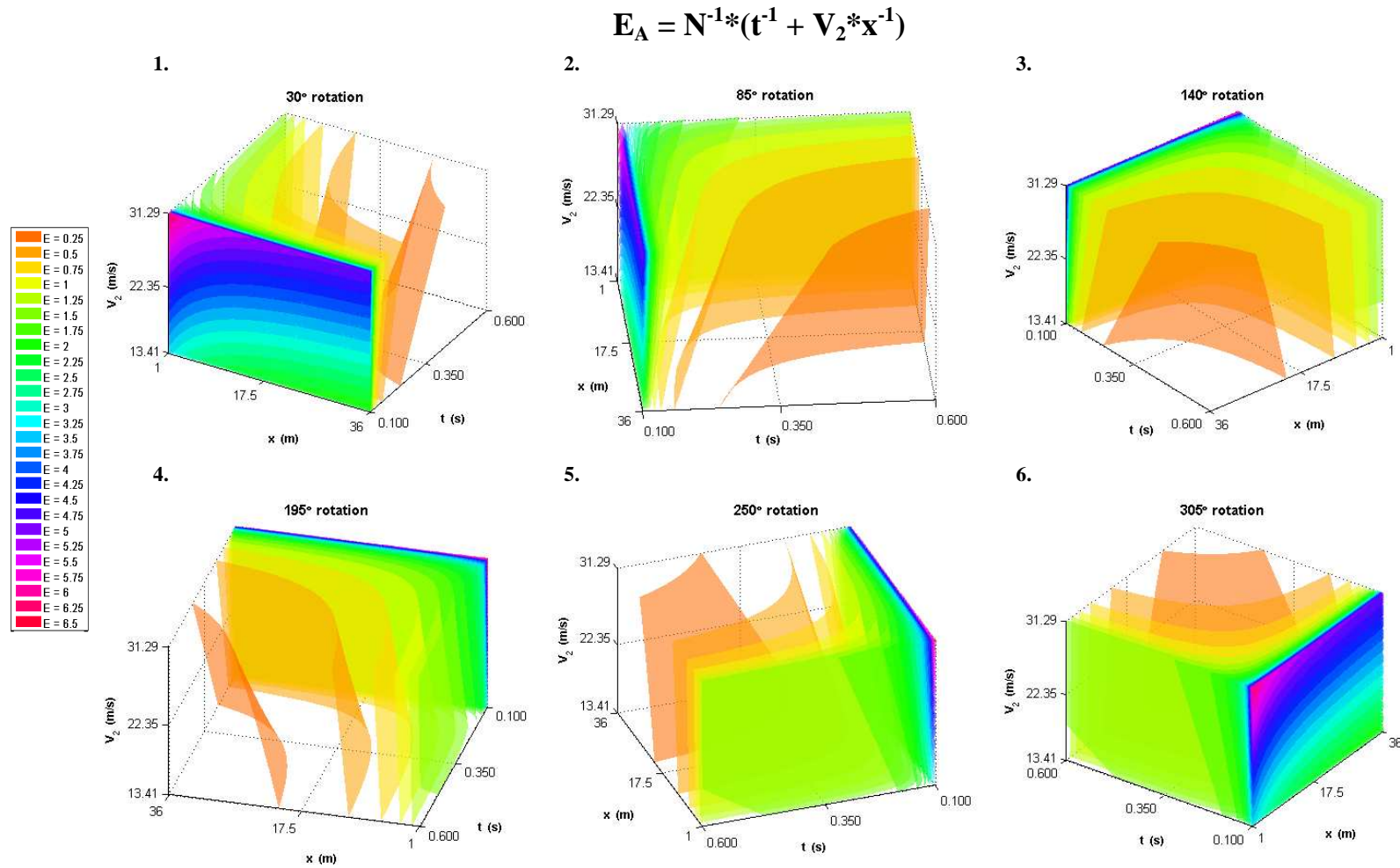

Figure 3 – Edge rate isosurfaces under Case A

$$E_B = N^{-1} * (t^{-1} - V_2 * X^{-1})$$

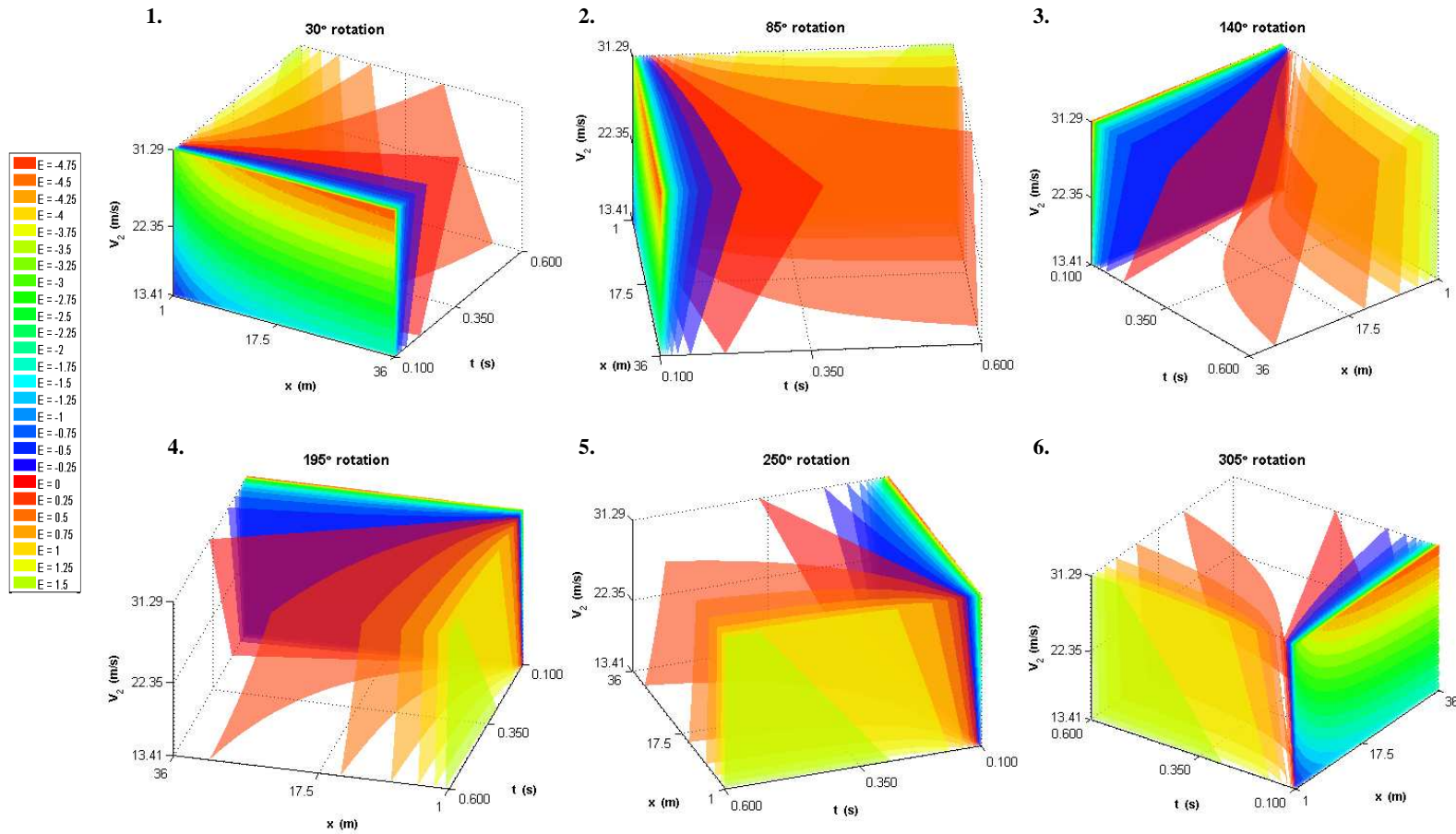

Figure 4 – Edge rate isosurfaces under Case B

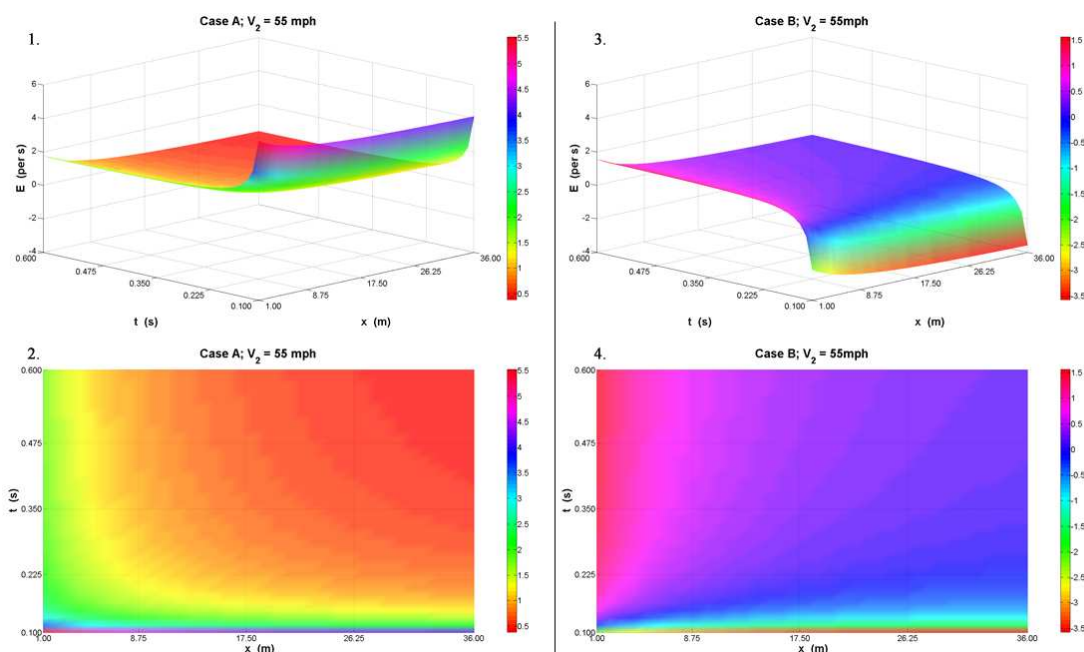

Figure 5 – Edge rates at $V_2 \approx 55$ mph

Note: Graphs 2 and 4 in the above figure are top views of graphs 1 and 3, respectively. They depict $E = f(x, t, V_2)$ with $V_2 \approx 55$ mph

The method of implementing a particular edge rate for the proposed perceptual countermeasure was further limited by the lack of control over a driver's speed. When dealing with moving waves of lit warning lights, different driving speeds yield different relative velocities, which can cause the waves to move in a direction not intended for the work zone (e.g., lights moving away from drivers rather than toward them). With the bounded parameters, edge rates that were studied by Owen, Larish and Flach in the 1980s and 1990s (0.05 to 1.5 edges per second) could be investigated with synchronized flashing beacons but only under **Case A**, where waves of lit beacons would appear to move toward the driver. Also, since the main focus of this thesis was to investigate a method for reducing mean driving speeds and variation in speed, investigating **Case B**,

which in theory (Vercursyssen et al., 1995) could increase driving speeds, was not an option.

Table 5 – Parameters for determining edge rate

Variable	Range of Possible Values	Comments
Flash Rate (f)	1.2 to 1 second per cycle (0.833 to 1 Hz)	<ul style="list-style-type: none"> Constrained by FHWA guidelines for TTC and general norms concerning photosensitive epilepsy. The flashing must not startle or confuse motorists and highway workers.
Flash on and off durations (f_{on} and f_{off})	$f_{on} \in [0.1, 0.6]$ s and $f_{on} + f_{off} = f$	<ul style="list-style-type: none"> On and off durations constitute a cycle and can be any fraction that adds up to the flash rate. For simplicity it can be fixed as equal on-off rate. On and off durations must generate the perception of successively lit beacons as being linked to form a wave. Units: seconds per cycle or hertz (Hz)
Distance between successive beacons or inter-beacon distance (x)	If posted speed limit is 90 km/h or 55 mph, $x \in [1, 36]$ m Or, $x \in [3, 110]$ feet	<ul style="list-style-type: none"> Constrained by FHWA guideline, "The maximum distance in meters (feet) between devices in a taper should not exceed 0.2 times the speed limit in km/h (1.0 times the speed limit in mph)" as prescribed in Tables 6H.3 and 6H.4 of the MUTCD. Minimum value is arbitrarily chosen as 1 meter. Units: meters (m)
Delay between successive lighting up of beacons (t)	$t \leq f_{on}$ s i.e. $t \leq 0.6$ s	<ul style="list-style-type: none"> Time delay must be adjusted to generate the perception of successively lit (groups of) beacons being linked to form a wave. Units: seconds (s)
Driver Velocity (V_2)	$V_2 \in [30, 70]$ mph Or, $V_2 \in [13.41, 31.29]$ m/s	<ul style="list-style-type: none"> Assumed to vary between 30 mph and 70 mph Units: meters per second (m/s)
Relative Velocity (V_1)	If above values of x and t are used, $V_1 \in [1.67, 360]$ m/s	<ul style="list-style-type: none"> Velocity of waves of lit warning lights is dependent on values of x and t. Units: meters per seconds (m/s)
Wave Length (L)	$L = N * x$ where $N > 2$ and $N \in \mathbb{N}$ Assume, $L = 6x$	<ul style="list-style-type: none"> Set of lit beacons and set of dimmed beacons together constitute a wave which is a minimum of two. Units: meters (m)
Edge Rate (E)	Case A: $E_A = [0.34, 6.88]$ edges/s Case B: $E_B = [-4.94, 1.60]$ edged/s	<ul style="list-style-type: none"> Edge rate is directly proportional to relative velocity, which can change its direction of motion depending on driver speed. It is advocated that synchronized flashing beacons be used with extreme caution under Case B. Units: edges per second (edges/s)

Summary

Work zone safety was identified as a prevalent and important issue that needs focus specifically on speeding and speed variation, particularly in low-visibility conditions. A literature review of various countermeasures aimed at improving work zone safety revealed gaps in the area of non-obtrusive countermeasures. Perceptual countermeasures with synchronized flashing warning lights were identified as a cost-effective measure that could overcome the shortcomings of perceptual countermeasures with pavement markings, and then ranges of parameters for implementing waves of lit warning lights were derived. With these a set of hypotheses and a simulator-based experimental study were generated to evaluate perceptual countermeasures with synchronized flashing lights, which are explained in the following sections.

CHAPTER II HYPOTHESIS

A hypothesis of the form $H_0: m_1 = m_2 = m_3 = \dots = m_n$ where $m_1, m_2, m_3, \dots, m_n$ are mean speeds within work zones 1, 2, 3, ..., n with varying conditions was found worthy of rejection with statistically valid reasoning by Vercurysen et al. (1995). However, this hypothesis was retested here for verification.

Building upon the work done by Vercurysen et al. and from the discussion on perceptual countermeasures and edge rate, it was hypothesized that increasing the number of discontinuities seen from 1 to 1.5 edges/second would give drivers a perception of driving at higher speeds. This would let the driver slow down the vehicle. It was assumed that any perception of "higher" speed would have been evidenced by:

1. Lowered mean speeds within work zones reaching closer to the posted speed limit
2. Reduced incidences of sudden increases and decreases in speed or slower changes in speed with lesser magnitudes of change

A specific hypothesis about gender differences was not constructed, as tuning a perceptual countermeasure for either gender would not serve a practical purpose. To investigate the possible merit of using perceptual countermeasures with synchronized warning lights or beacons, the following experiment was devised based on the hypotheses.

CHAPTER III METHOD

While test tracks and on-road studies offer one way to evaluate different interventions, they are subject to varying environmental conditions and may pose a significant risk to test participants and researchers. Driving simulators offer a viable and pragmatic approach. This study used a driving simulator because it provided an inexpensive and systematic means of manipulating multiple test conditions, the ability to repeat the experiment under identical conditions for different participants, and most importantly, it ensured the test participants' and researchers' safety.

Just as test tracks and on-road studies have limits, so do driving simulators. These include concerns of scenario realism, simulator sickness and representativeness of driving scenarios. Increasingly powerful computing systems make increasingly realistic scenarios possible, thereby mitigating some concerns of scenario realism. Simulator sickness can adversely affect simulator results, but it is mitigated by screening participants for simulator sickness. The ultimate validity of simulator data remains an empirical matter that depends on the match of simulator features and the nature of the particular driving task. Hoskins and El-Gindy (2006) and Kaptein et al. (1996) elucidate the concept of the validity of driving simulators and assert that driving simulators are a valuable research tool in human factors studies. For these reasons, a simulator-based experiment was adopted and experimental data was collected. The following sections explain participant demographics, the experimental design, tasks and procedure.

Participants

A total of 16 individuals, eight male and eight female, within the age group of 30 and 50 were recruited to participate in this study. The demographics of the participants were:

Table 6 - Participant demographics

Gender	Number of participants	Mean Age	Standard Deviation
Female	8	41.0	4.3
Male	8	41.6	4.0
Total	16	41.3	4.1

Advertisements about the study were listed in the Noon News of the University of Iowa Health Clinics and were also posted on public message boards. Word of mouth and emails to colleagues were also used. Participants were screened through a telephone interview on the basis of having an active driver's license, being within the age group of 30 and 50, having driven for more than 5 years and driving at least 3 times per week. They self-reported to have normal or corrected-to-normal vision. They self-reported not to have been diagnosed with any type of seizures or epilepsy at any point in their lifetime nor to have frequent headaches or migraines. They were required not to be claustrophobic and not to be pregnant (females) at the time of participating in the study. The aim of the screening process was to gain access to a population of roadway users who were representative of a majority segment of the driving population in the Midwest, which is the age group of 30- to 50-year-old drivers. This age group was also chosen to control for large-scale variability in driving attitudes due to differences in age and experience, which would produce greater disparity within 16 participants compared to a larger set of participants. The participants were given a nominal compensation of \$20 per hour for their time.

Experimental variables

The study had a repeated measure, within-subjects experimental design. The independent variables included "work zone type" (asynchronous, moving and static), test

run number, work zone sequence, repetition, presence of lead vehicle and gender. The dependent variables were average speed (in mph) and the frequency component of the speed within the work zones. The simulator also recorded other objective measures such as lane deviation, steering wheel angle, usage of accelerator and brake pedal, etc.

Experimental design and tasks

The Manual on Uniform Traffic Control Devices (MUTCD) by the FHWA (US DOT – FHWA, 2007) provides guidelines and specifications to various transportation and highway agencies. Section 6 of the MUTCD describes temporary traffic control (TTC) measures concerning work zones and traffic incidents. Based on these guidelines, a test run within a virtual environment depicting a typical Midwestern highway was designed.

A work zone with a particular lighting condition was identified as a “work zone type.” It had three levels, and all three work zone types appeared in each of the four test runs for each participant. The three work zone types in a test run evaluated existing practices to the proposed method of synchronized warning lights. These were:

- i. Moving lights (M) – Work zone warning lights on jersey barriers that flashed in a synchronized pattern moving toward the driver.
- ii. Asynchronous lights (A) – Work zone warning lights on jersey barriers that flashed at random without a definite pattern.
- iii. Static lights (S) – Work zone warning lights on jersey barriers that were constantly on.

The static lights condition depicted the prevalent practice of using warning lights in non-flashing mode, which is a standard prescribed by *Section 6F.78* of the MUTCD. The asynchronous flashing lights depicted a less common practice used only in extremely hazardous situations where each warning light is set into flashing mode individually. This

typically generates a random or asynchronous pattern. The MUTCD does not have guidelines on synchronizing them.

Two types of test runs were created: one investigating speeding behavior “without lead vehicle” (N1 - L3) and another “with lead vehicle” (L1 - L3). Both test runs consisted of 9.5 miles of straight and level highway with three work zones of two mile length (each of a particular type) spaced one mile apart. Figure 6 better elucidates the virtual scenario or, in other words, test run design.

The sequence in which a work zone type appeared in a test run was randomized using two 3x3 Latin Squares (see Table 7) giving all the possible combinations of work zone sequences among six test runs. Four test runs were chosen of the six such that a participant would perform each type of test run twice (first measure and repeated measure). For each participant, a set of four test runs was assigned randomly and was counter balanced so that an equal portion of male and female participants drove through a without-lead-vehicle test run (N1, N2, or N3) either before or after a with-lead-vehicle test run (L1, L2, or L3). This randomization is shown in Appendix B.

Participants were tasked to drive through four test runs. Two were through a virtual scenario depicting typical Midwestern highway conditions with a lead vehicle, and the other was to drive through the same scenario without a lead vehicle. The experiment therefore had a repeated measure, within-subjects experimental design.

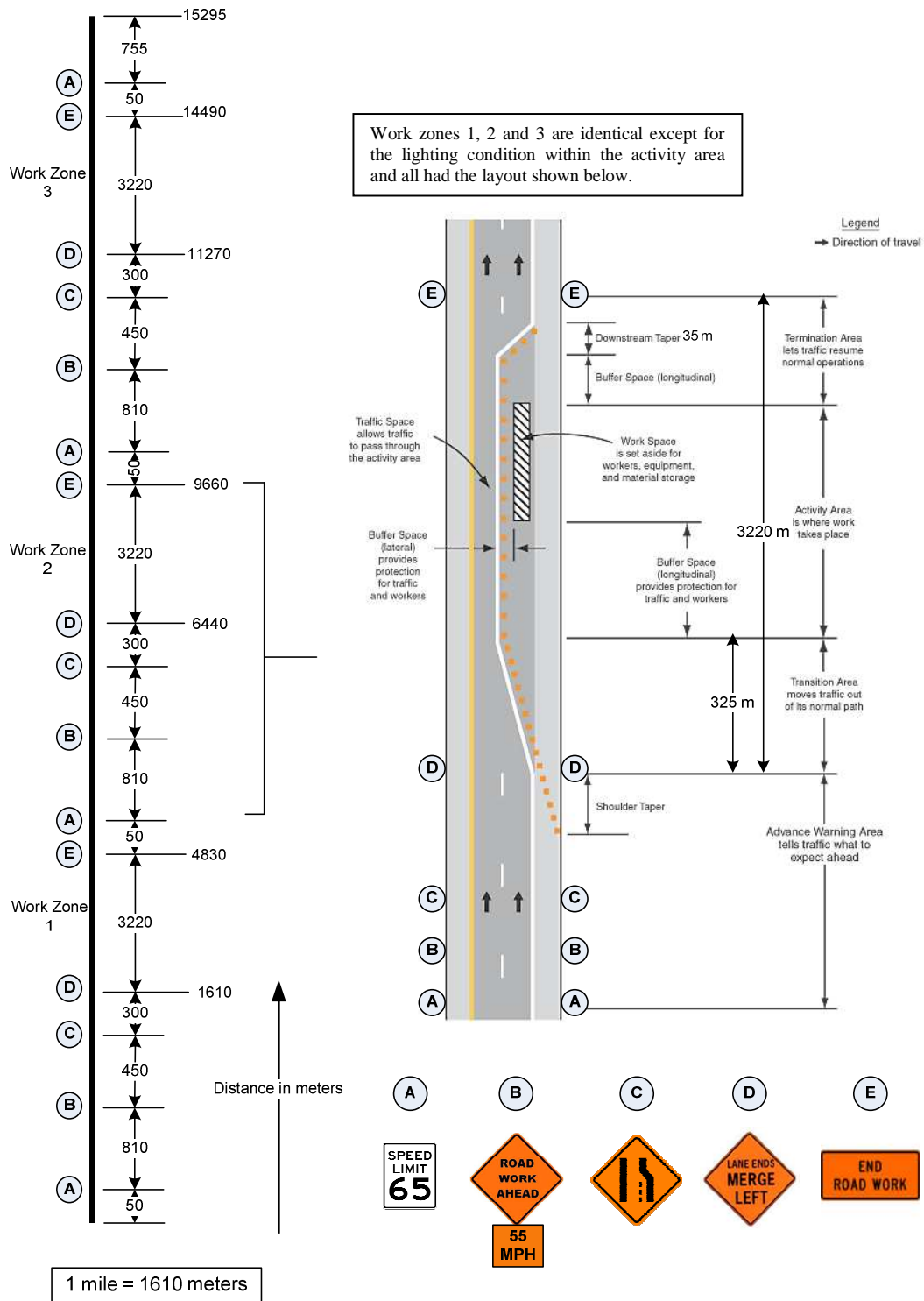

Figure 6 – Test run design

Table 7 - Latin Squares to determine the order of work zone type

Lead vehicle	Test run	Work zone sequence
Absent	N1	M A S
	N2	S M A
	N3	A S M
Present	L1	S A M
	L2	A M S
	L3	M S A

Apparatus and driving environment

The experiments were conducted using a fixed-base, medium-fidelity driving simulator using a four-door Ford Sable cab and Drive Safety's® HyperDrive™ authoring software. A rear-projection screen with 1024 x 768 resolution, 122.88 cm x 92.16 cm screen size, located approximately 140 cm in front of the drivers produced a driving scene that spanned approximately 50 degrees of visual field. Participants' eye-height was approximately 130 cm above ground. The simulator collected data at 60 Hz, and the examiner could communicate with the participant via a two-way microphone and speaker system during the experiment. The visual scene consisted of a virtual environment depicting a typical Midwest interstate highway with three lanes in each direction along with a wide median and typical signage with low-visibility conditions as shown in Figure 8. The driving simulator had a limit of 50 polygons, so only 25 warning lights could be created. The warning lights were created ahead of the driver and destroyed behind them dynamically so that the entire length of the work zone could have warning lights placed over jersey barriers of 56 inch height. The driving scenarios used almost black-colored

fog (RGB 15, 5, 20) at a distance of 175 meters that modeled late-night conditions lacking visible traffic.



Figure 7 - Driving simulator apparatus

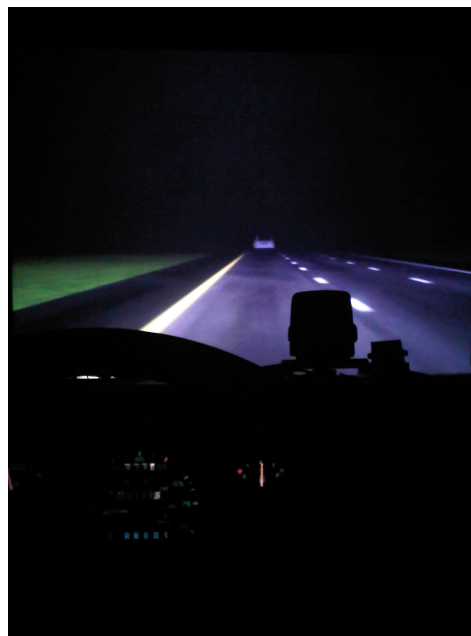

Figure 8 - View from driver's perspective

The fog distance also concealed the sudden appearance of warning lights. The warning lights were placed 9 meters apart because 10 meter was too far (the waves broke down) and 8 meters was too close (the fog needed to be much closer to conceal the dynamic creation process). The warning lights were created with two two-dimensional polygons: a bright yellow-amber hexagonal polygon overlaid on a dull orange-amber hexagonal polygon. The bright polygon depicted the on state and the dull one the off state of the warning light. As the polygons were created in the virtual environment, their minimum dimensions projected on the screen were 0.32 cm x 0.32 cm (0.13 degrees of visual angle), and as the participants drove closer to the polygons, their maximum projected dimensions were 6.4 cm x 6.4 cm (2.62 degrees of visual angle).

Moving warning lights were created by making the bright polygon visible for f_{on} seconds and invisible for f_{off} seconds, creating a flashing effect. With an apparatus-driven constraint on the distance between successive polygons (beacons), their on-off durations were adjusted to 0.433 and 0.466 seconds, respectively. Time delay was set to 0.11 seconds through exploratory methods and with reference to the model depicted in Figure 5 to achieve a reasonable wavelike apparent motion. This produced an edge rate of 1.97 edges/s at 55 mph (24.59 m/s).

Asynchronous warning lights were created by fixing the off duration of each beacon to 0.5 seconds and lighting all bright polygons at once with a randomly generated on duration using the formula:

$$f_{on} = \text{random}() * 0.4 + 0.2 \quad \dots (11)$$

The function **random**() generated a number between 0 and 1 sampled from a normal distribution. The above formula ensured that f_{on} was less than 0.6 seconds and that lights did not accidentally synchronize.

Static lights were created by making the bright polygons visible throughout the test runs.

Procedure

Participants were provided with the informed consent documents upon their arrival and told that they would be driving in a virtual environment depicting a highway. After their consent was received, they were directed into the driving simulator and instructed on its operation. They were then allowed to familiarize themselves with the simulator in a practice run that lasted for five minutes. If the participants felt comfortable, they were allowed to continue with the test runs. Before each test run, the participants were instructed to “drive as they would in their own car in the real world.” They were instructed to put the car into drive when they were ready to do so and not pass any vehicle that might be in front of them. They were also instructed to remain in the leftmost lane until asked to stop and put the vehicle into park. The participants started off in the middle of the leftmost lane. Each drive lasted for 12 to 15 minutes. After the second test drive, the participants were given a five-minute break. At the end of the four test runs, the participants were given a questionnaire. At the end of the session, participants filled out a payment form before leaving. The entire session lasted for 1.5 to 2 hours.

CHAPTER IV RESULTS AND ANALYSIS

Under each of the two experimental tasks – one, driving on a highway with a lead vehicle and the other without a lead vehicle – 16 participants' mean speeds in each of the three work zone types with a repeated measures component yielded 96 observations ($16 \times 3 \times 2 = 96$ observations). The headway data recorded was corrupted due to possible apparatus failure and was therefore not utilized in the analysis. The 96 observations were analyzed separately under the different experimental tasks and are presented separately. The analysis was done in three stages. The first was to verify the findings of Vercurysen et al. (1995), and the second was to investigate the frequency component of the speed profiles within the work zones. This method was deemed suitable because simple observation of the profiles appeared to be sinusoidal and, upon further investigation, the key area within the work zone was found suitable for Fourier analysis. The third stage was a post hoc analysis investigating the drivers' behavior prior to entering the work zone using a linear mixed effects (LME) model.

The instantaneous speed collected at 60 Hz was reduced by averaging the speeds every one tenth of a mile for each run. This procedure of data reduction matches the approach used by Vercurysen et al. (1995). These reduced data points were then averaged within the work zones to determine the participants' mean driving speed in the work zone. This data was analyzed for normality using the QQ-Norm function of the statistical analysis package R version 2.8.0. and was found to be non-normal with heavy tails. An analysis of variance (ANOVA) was therefore not very suitable. It also did not follow from the hypotheses. However, by assuming robustness of ANOVA (Stiger et al., 1998) and in order to confirm the tests done by Vercurysen et al., an ANOVA was conducted considering the null hypothesis that the sampled mean speeds of all participants within the three work zones were drawn from the same underlying distribution and that they had identical population means. In the experimental task with a lead vehicle, the results did not reach significance with $F(2,93) = 0.3, p = 0.744$. Also, in

the experimental task without a lead vehicle, the results did not reach significance with $F(2,93) = 0.086$, $p = 0.918$. The ANOVA of mean speeds for test runs with and without a lead vehicle does not provide sufficient evidence to doubt the null hypothesis, hence the null is retained. This showed that work zone type was not a statistically significant factor predicting variation in mean speeds within the work zone. These preliminary treatments of the data are presented in Appendix C.

To investigate the hypothesis of whether the intervention had a “calming effect” on drivers’ speeding behavior, a Fourier analysis of the speed profiles within each work zone was conducted. The data were analyzed according to the scheme shown in Figure 9.

Participants’ speed data between the points marked D and E in Figure 6 within each work zone was found to be linear time invariant (LTI). The power of the dominant frequencies of speed in two bands was observed. The low-medium frequency band was defined as 0.05 Hz to 0.15 Hz, and a medium-high frequency band was defined as 0.15 Hz to 0.5 Hz (McGehee et al., 2004).

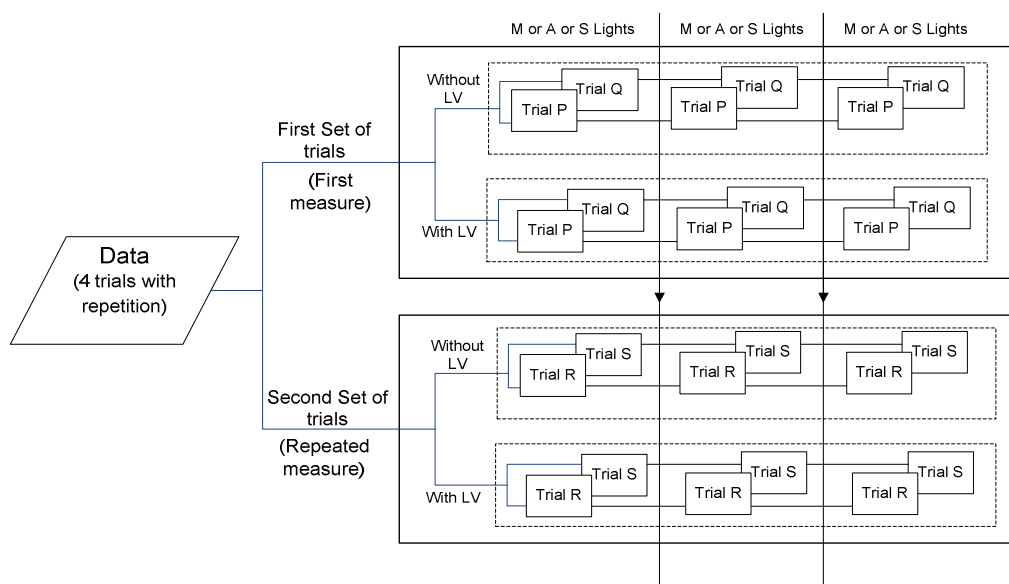

Figure 9 - Data analysis scheme

Figures 10 and 11 show the frequency component of the speed data that were analyzed using the Fourier Fast Transform (FFT) algorithm of Matlab 2009a. The FFT implemented a discrete Fourier analysis sampled at 30 Hz (half of original data collection rate) and illustrated that a few of the participants were drastically influenced by moving and asynchronous lights in test runs, in general evidenced by higher powers in the very low frequency range of 0.1×10^{-3} to 0.5×10^{-3} Hz, as opposed to higher frequencies of 0.5×10^{-3} to 1.5×10^{-3} Hz. It is argued here that this is characteristic of “calm driving.” These calmer participants’ speed profile within the work zone can be compared to a sinusoidal wave with large wavelengths without high-frequency sinusoidal waves mixed into it.

Specifically, in the static lights condition most participants exhibited rapid increases and decreases in speeds among test runs without a lead vehicle. This is speculated to happen as participants looked at the speedometer and realized they were going too fast or too slow compared to the posted speed limit. Thus, they made a “corrective” action.

The rapid change in speed is similar to an under-damped second-order system exhibiting the phenomenon of “hunting.” As such, this behavior is termed as “not calm.”

In the test runs with a lead vehicle, the above conditions were observed, but practically all drivers seemed to exhibit calm driving behavior within the work zones. This is likely due to the systematically programmed lead vehicle that became a “shadow vehicle” restricting and guiding the participants who were observed to have been mostly tailgating the lead vehicle. This, however, caused the warning lights to be occluded by the lead vehicle, which is a simple but significant failure in the use of perceptual countermeasures.

Post hoc analysis of the data using an LME model revealed that the speed just before entering the work zone and repetition were statistically significant factors that accounted for a sizable variation in the mean speed within the work zones.

Participants' speed profiles through each test run revealed that all participants did lower their speed as they entered the work zones and increase it as they exited the work zone. Their speeds in the test runs with lead vehicles were drastically reined by the lead vehicle, the work zone layout and the instruction to not overtake the lead vehicle. The following analysis therefore concentrates on the test runs without lead vehicles. A relation between participants' mean speed and the entry speed was examined with an LME model constructed using the "lme function" of "nlme Library" in R.

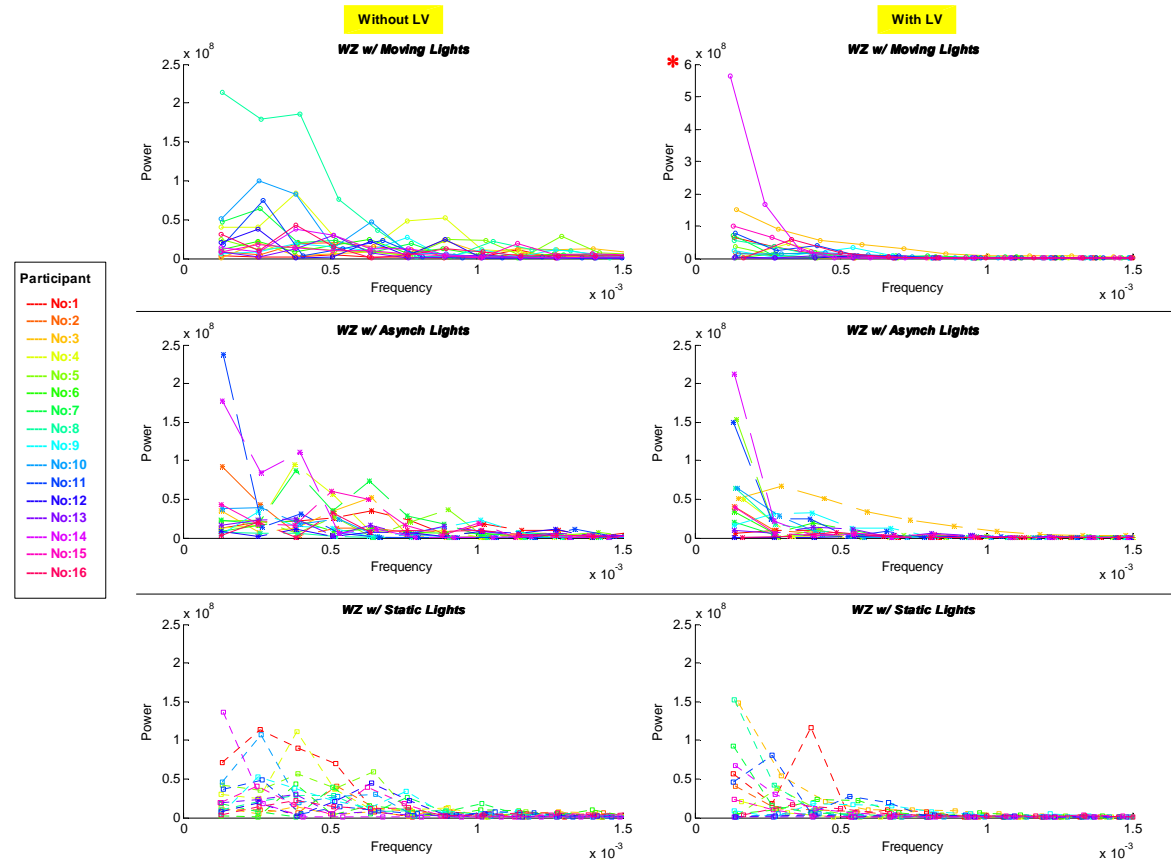

Figure 10 - Fourier analysis of first set of measures

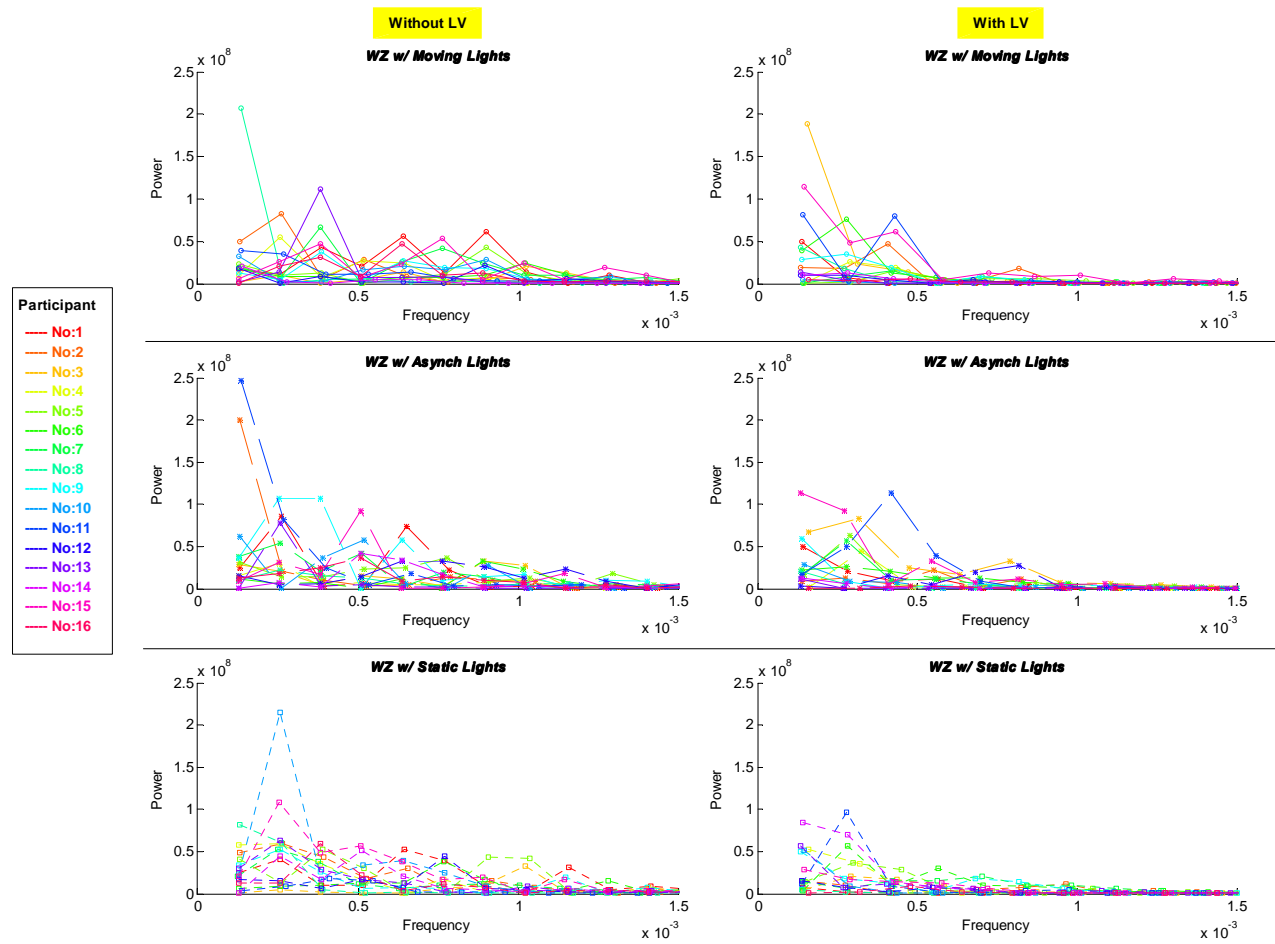

Figure 11 - Fourier analysis of repeated measure

The post hoc analysis of the mean speeds within each work zone was conducted with entry speed, gender and repetition as fixed effects and participants as random effects, as they represent randomly sampled drivers from a population of middle-aged drivers in the Midwest in the US. Work zone type was omitted since there was already sufficient evidence to suggest that it did not contribute greatly to the variation in mean speeds in the experiment. Interaction terms were also omitted to conserve degrees of freedom and because there was not a particular reason to suspect a significant interaction. Equation 12 represents the model.

$$Y = \mu + \alpha + \beta + \gamma + \rho \quad \dots (12)$$

where, Y – Mean speed

μ – Average of all mean speeds

α – Participant

β – Entry speed

γ – Gender (factor with levels ‘male’ and ‘female’)

ρ – Repeated measure (factor with levels ‘yes’ and ‘no’)

The results of the regression are summarized in Table 8 and an ANOVA table is provided in Table 9. Gender was not observed as a statistically significant factor at 0.05 level. Entry speed and repetition were statistically significant at 0.01 level, where mean speed increased by 0.32 mph for every 1 mph increase in entry speed and by 1.06 mph due to a repetition.

Table 8 - Linear mixed effects model summary table

Fixed effects: Entry Speed, Gender and Repetition					
Random effects: Participants					
	Value	Std.Error	DF	t-value	p-value
(Intercept)	40.010	3.6649	78	10.917	<.0001
Entry Speed	0.3246	0.0540	78	6.0116	<.0001
Gender	-0.0897	1.3137	14	-0.0682	0.9466
Repetition	1.0662	0.3108	77	3.4304	0.0010

Table 9 - Anova of linear mixed effects model

	numDF	denDF	F-value	p-value
(Intercept)	1	78	8806.808	<.0001
Entry Speed	1	78	34.206	<.0001
Gender	1	14	0.008	0.9313
Repetition	1	77	11.767	0.9718

CHAPTER V DISCUSSION

The limitation of the apparatus's visual display capabilities, usability and programmability, along with the design of the experiment, are thought to be contributing factors in the lack of strong and definitive evidence from the collected data to prove or disprove the study's hypotheses. While between-subjects design could have given a more robust experimental design, it would have required a much greater number of participants, adding to financial requirements. The within-subjects design was not fully supported by the selection of four test runs out of the possible six to administer to each participant.

The results of the data analyses do promote certain notions. The discussion is divided into sections that follow from the analyses.

Results of the ANOVA and graphical analyses

The results did not provide strong evidence to support or disprove the hypothesis that use of perceptual countermeasures affords a significant reduction in mean speed or reduces the fluctuations in speed. Figures in Appendix D indicate that three groups of mean speed are distinguishable within the work zones: 1) 55 to 60 mph, 2) 60 to 65 mph and 3) speeds greater than 65 mph. Comparing participants' speed profiles and periodograms with this information in mind reveals the following:

- a) In test runs without lead vehicle
 - i) Participants whose averaged mean speeds were lower than 65 mph had more periodic variation in speeds compared to those with averaged mean speed higher than 65 mph. Some of this variation in speed may have been due to a lack of adaptation to the driving apparatus. A number of these participants commented that the steering wheel and brakes were too sensitive. The variation in speed may stem from their struggle to control the simulated vehicle. A medium-frequency sine wave forms the dominant component of

speed profiles of Participants 6-F, 7-F, 9-M, 11-M, 12-M and 13-M as seen in their periodograms (Appendix D).

- ii) Participants whose averaged mean speeds were higher than 65 mph showed very little variation in speeds. These same individuals did not mention any discomfort with the apparatus. Their ability to control the simulated vehicle effectively may have added to their desire to drive fast and their confidence in reacting to a possible situation like a deer crossing the road. There were no such incidences planned into the experimental scenarios. A low-frequency sine wave forms the dominant component of the speed profiles of Participants 3-F, 4-F, 10-M and 16-M. This behavior may also be in part because specific instructions were not given to the participants to maintain a particular speed. It was assumed such instructions would hinder their natural driving behavior on highways. Clearly, individual differences have an overriding effect, but the observation of driving speeds above 70 mph within the work zones was surprising. The most astonishing finding was that these participants were quite unaware of their driving speed, and they underestimated their mean speed by roughly 10 mph. Also, in the questionnaire, two of them reported looking at the speedometer between three to five times, one reported one to two times, and the fourth participant reported looking at it more than 10 times during the course of each work zone.
- b) In test runs with lead vehicles
 - i) Participants often maintained a headway over five seconds, but they all tried to achieve the maximum speed possible within the two mile long work zones, where they eventually caught up to the lead vehicle and were restricted by it. The lead vehicle acted as a shadow vehicle, and it appears that a shadow vehicle can very successfully restrict traffic speed regardless of work zone conditions.

- ii) A shadow vehicle or a slow driver might “aggravate” some drivers. Participants who exhibited speeding behavior in test runs without lead vehicles also exhibited higher variations in speed as well as more rapid acceleration and deceleration patterns compared to other participants.

Results of the Fourier analysis

The Fourier analysis shows a more tangible approach to analyzing nonlinear speed data that is typically reminiscent of sinusoidal waves. This form of analysis is not typical, yet it gives a more complete picture of the set of data analyzed because more number of data points can be fed into the analysis. The typical drawbacks of ANOVA include limited degrees of freedom, sensitivity to non normality, and need for mathematical adjustments if the number of samples are too few or too many. The analysis did elucidate individual differences in driving where a number of drivers (both male and female) were drastically affected by blinking lights of any kind, and their behavior was better modeled by a wave within the low-frequency range with an amplitude greater than 1.5×10^6 units. This contrasts with all drivers whose behavior was modeled by a wave with amplitudes that always stayed below 1.5×10^6 units when driving in the static light condition. This analysis does provide evidence that shows the “calming effect” of warning lights used as a perceptual countermeasure in a driving simulator.

Results of the linear mixed effects (LME) model

An important outcome of the study and a result from the LME model was evidence of drivers continuing to drive through work zones at speeds closer to their entry speed. The same observation is supported by Brewer et al. (2006), who noticed that “drivers will generally maintain the speed at which they were traveling before entering the work zone, regardless of the posted work zone speed limit.” This would point to the necessity of implementing countermeasures to speeding well in advance of the work

zone. How well in advance they must be implemented and whether they give a notion of level of activity in the work zone would be important questions to consider.

Repetition was also a significant predictor of mean speeds. It is suspected that the participants in the experiment learned through repetition that the roadway was generally empty and that moving through the work zones at higher speeds was safe. This might also be the case in real-world situations where frequent commuters would show a greater tendency toward speeding because their assessment of the risks of traveling through the work zone at high speeds (risk of having an accident, being fined, etc.) would diminish with each repetition or daily commute.

CHAPTER VI CONCLUSION

Through an extensive literature survey on work zone interventions, a number of key areas of research were identified. These were:

- Managing variability in driving speeds
- Taper design and its effect on traffic regulation
- Effect of distance of signs from the work zone on driving behavior and driver attentiveness
- Effect of different TTC devices on driving behavior
- Effect of lateral buffer distance
- Perceptual countermeasures

Of these, the use of perceptual countermeasures provided the possibility of implementing cost-effective means of mitigating speeding behavior as well as managing variability in speeds due to their supposed “calming effects.” To overcome the drawbacks of pavement-marking-based perceptual countermeasures, the use of flashing beacons was investigated. Flashing beacons would also be more conspicuous and visible in poor visibility conditions and at night. The method of synchronizing flashing beacons to generate waves of lit beacons was proposed by Vercurysen et al. (1995). Their study was extended by describing the theoretical aspects of perceptual countermeasures. This included reviewing the concept of edge rate and the studies by Denton (1980), Owen (1982), and Larish and Flach (1990). Parameters governing edge rate of waves generated by flashing beacons and their limiting conditions were identified (see Table 5 for a summary). Edge rate is ultimately a function of inter-beacon distance, time delay between successively lit beacons and driver speed. An important outcome of this exploration was the fact that using synchronized flashing beacons to generate waves that move away from the driver is very difficult and should be avoided because the waves are likely to change their direction of apparent motion as motorists’ speeds increase.

An experiment was devised to verify the findings of Vercurysen et al. (1995) and to identify possible benefits of synchronized flashing lights. The experiment was conducted with 16 participants, eight of which were male and eight of which were female, all within 30 to 50 years of age.

In general, the experiment was successful in providing an insight into the efficacy of using perceptual countermeasures with synchronized flashing to mitigate speeding. However, due to the technological difficulties with the apparatus and the experimental design, the observed effect was weak. In comparison to the study conducted by Vercurysen et al. (1995), this study implemented flashing beacons on only one side of the road as opposed to both sides, which could also be one of the reasons for observing a weak or null effect. The experiment could have been more robust as a between-subjects, factorial design examining synchronized flashing warning lights versus continuously lit warning lights. It is also important to note that learning and individual differences play an important role in driving, which would make a notable impact on the novelty effect of the perceptual countermeasure. This effect remains to be investigated.

The outcomes of this study can be used to better design experiments that can investigate different types of perceptual countermeasures and other interventions involving flashing beacons in more advanced driving simulators, on test tracks or in the field.

The FHWA-MUTCD, however, restricts the use of flashing beacons. It directs their usage for warning of extremely hazardous situations and says not to use them for demarcating warning zones. Inclement weather conditions with poor-visibility conditions are likely to lead to a hazardous situation around work zones where flashing beacons would be warranted. With synchronized flashing beacons, the work zone can be demarcated with appropriate TTC devices and the beacons can be lit in low- and high-intensity settings instead of on and off settings to create waves of moving lights as well as continuously visible lights. Concerns of liability due to technical failure of the waves to

synchronize appropriately also exist. However, it is estimated that technological advancements in the future will reasonably overcome such technical issues. A greater concern in using this intervention and perceptual countermeasures in general are their occlusion due to a lead vehicle. If the pavement markings or waves of lights are not seen, the intervention fails. These concerns must be taken into account when evaluating currently available vendor products that make use of synchronized warning lights (see Fitzsimmons et al. [2009] for a review).

Future research can investigate the possible semantic meaning of waves of flashing lights perceived by drivers and their possible use in communicating speed like radar-triggered CMS to make drivers more aware of their speed. Another important avenue for research is reevaluating the assumptions used for designing tapers and speed limits. If US highways are to match the design of highways such as the German Autobahn, greater efforts must be made to reduce individual speed variation. Factors that contribute to individual differences in speeding and speed perception need to be further researched. It is possible that distraction can cause drivers to veer off their intended driving speed, leading them to later abruptly speed up or slow down. To investigate this, future tests may incorporate sudden events in the driving scenario, such as trucks merging into traffic from the work zone.

Work zones are likely to grow increasingly automated and “intelligent” in the future. This implies that interventions would incorporate information technology and sensor technology to cope with dynamically varying traffic and environmental conditions. In doing so, one must be aware that models used in devising those automated interventions would certainly be far from perfect. Therefore, constant revaluations of the interventions and a high degree of vigilance in monitoring them would be mandated.

APPENDIX A – ANECDOTE OF I-80 ACCIDENT

The following is an excerpt from the Post-Tribune dated March 17, 2010 (Post-Tribune Staff Report, 2010). It provides evidence correlating speeding and work zone accidents where a worker was fatally injured by a speeding motorist. Another important factor was the time of the incident, which was at night, at approximately 1:30 AM. This singular yet significant case shows that if mitigating factors such as speeding vehicle, presence of work zone, and nighttime conditions combine, a fatal incident is plausible.

Jenkins was working his nightly shift with Walsh Construction on Interstate 94/80 east of the Central Avenue exit, filling potholes in the middle westbound lane about 1:28 a.m. That was when a 1993 Mercury Cougar driven by Shannon came speeding through, according to the Indiana State Police. The vehicle struck Jenkins, and he was thrown through the car's windshield.

Another construction worker stood in front of the car to make sure it didn't move, Sgt. Ann Wojas said, and the driver then got out of the vehicle. He said a few words to the workers before running away on foot. Another worker tried to run after him but the driver escaped.

Jenkins died at the scene from severe blunt force trauma, according to police. Wojas said the accident wasn't just a case of a driver not paying attention. Safety barrels had been set up to block off the left and middle lanes, and the car drove in between them. When the vehicle, which Wojas said was going faster than the posted 45 mph speed limit, came up to construction vehicles blocking the workers from oncoming traffic, the car passed to the left instead of going back into the open right lane. The Mercury struck Jenkins as it was passing the construction vehicles, she said.

"He intentionally drove in the closed-off area, past the construction vehicles that were blocking the workers," she said.

The area had numerous signs and flashing alerts up for the public to advise the two lanes were closed. The work crew vehicles positioned by the workers included safety elements to protect them in case a car struck the construction vehicles, according to a police release.

The area had numerous signs and flashing alerts up for the public to advise the two lanes were closed. The work crew vehicles positioned by the workers included safety elements to protect them in case a car struck the construction vehicles, according to a police release.

APPENDIX B – ORDER OF TEST RUNS

Table B1 – Order of test runs

Participant No	Gender	Test Run 1	Test Run 2	Test Run 3	Test Run 4
2	F	L3	N1	L2	N2
6	F	L2	N3	L1	N2
1	F	L2	N1	N3	L3
5	F	L2	N2	N3	L1
3	F	N1	L3	L2	N3
7	F	N2	L1	L2	N3
4	F	N1	L1	N3	L2
8	F	N1	L1	N2	L3
10	M	L1	N1	L3	N3
14	M	L3	N2	L1	N3
9	M	L3	N3	L1	N2
13	M	L1	N2	L3	N2
11	M	N1	N3	N1	L2
15	M	N2	N1	N3	L3
12	M	N1	L3	L3	N1
16	M	N2	L3	L3	N2

Note: F – Female, M – Male, Ls – With lead vehicle, Ns – No lead vehicle

APPENDIX C – SUPPLEMENTARY DATA ANALYSIS

Table C1 – ANOVA of means speed for test runs with lead vehicle

Source	SS	df	MS	F	Prob > F
WZ Types	0.601	2	0.300	0.3	0.744
Error	94.321	93	1.014		
Total	94.922	95			

Table C2 – ANOVA of means speed for test runs without lead vehicle

Source	SS	df	MS	F	Prob > F
WZ Types	2.67	2	1.334	0.086	0.918
Error	1444.77	93	15.535		
Total	1447.43	95			

The data was checked for normality and it was assumed that it had constant variance. The data is non-normal as seen in Figure C1.

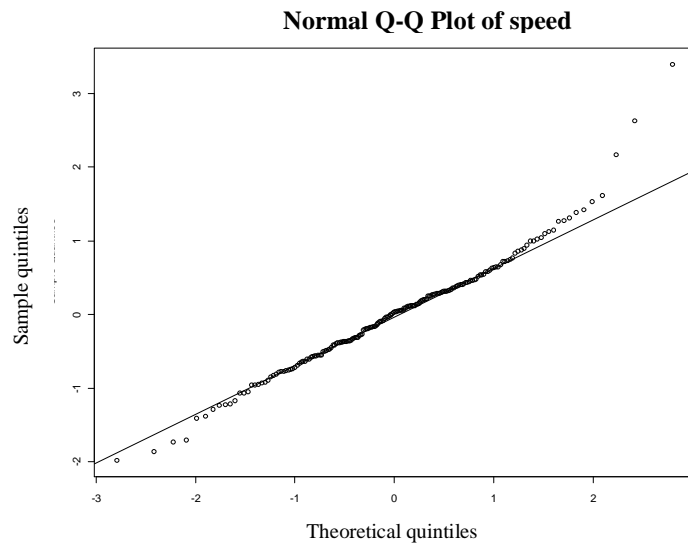

Figure C1 – Check for normality of speed data

Test runs with lead vehicle

Figure C2, with identifiers for mean speed within particular work zones as M – Moving, A – Asynchronous and S – Static lighting conditions, did not reveal any systematic ranking of letters across participants. This implies that the lighting condition did not have any particular effect on the mean speed of drivers within the work zones.

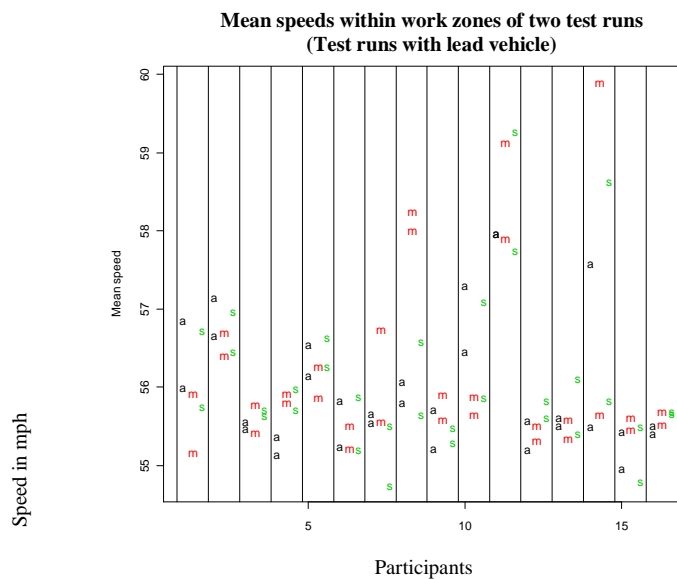

Figure C2 – Scatter plot of mean speeds within work zones in test runs with lead vehicles

Note: Y-Axis limits are between 55 and 60 mph. M – Moving lights; A – Asynchronous lights; S – Static lights

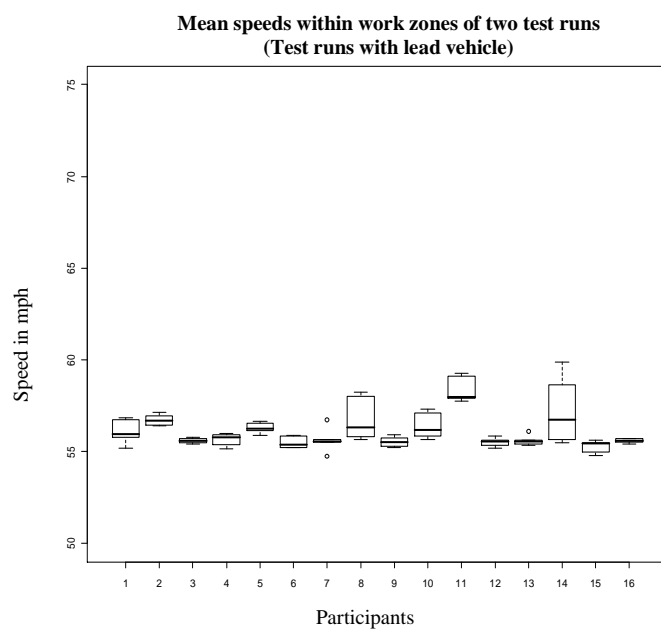

Figure C3 – Box plot of mean speeds within work zones in test runs with lead vehicles

Figure C3 shows that participants' overall speed was considerably restricted by the lead vehicle.

Test runs without lead vehicle

Figure C4 reveals that individual driving styles seem to account for participants' mean speeds to a larger extent than work zone type. Also, variance in mean speeds within work zones across participants was not nearly as constant as previously assumed. Some participants drove relatively slower or faster than others and showed very little variation in their mean speeds under different work zone conditions, while others showed considerably larger variations. A consistent ranking of the letters in Figure C4 – Graph 2 is not observed.

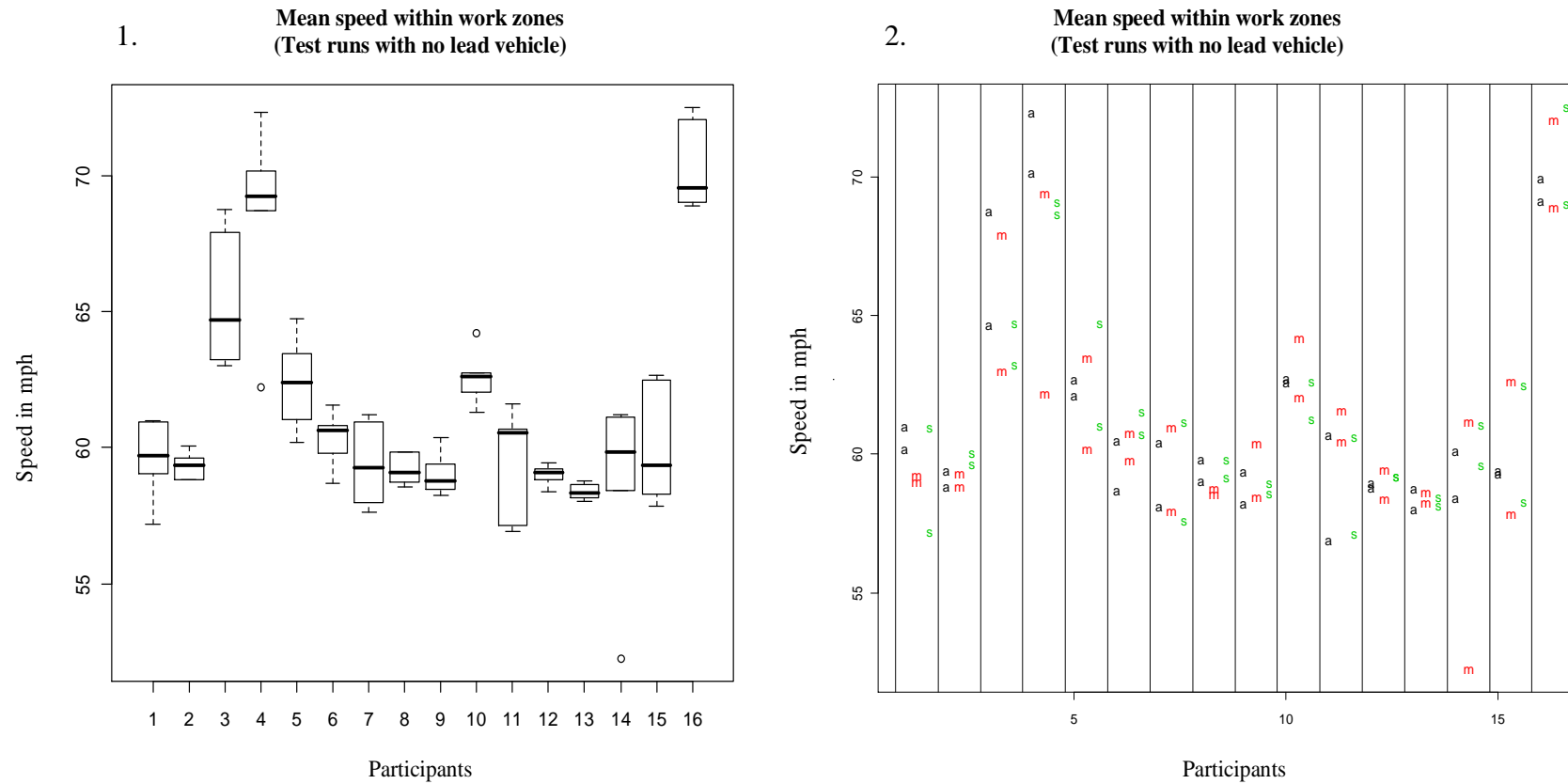

Figure C4 – Mean speeds within work zones in test runs without lead vehicles

Note: Y-Axis limits are between 50 and 75 mph. M – Moving lights; A – Asynchronous lights; S – Static lights

Average mean speeds of the two repetitions for the without-lead-vehicle test run were taken and ordered according to magnitude to better visualize participants' overall speeding behavior in work zones (see Figure C5). Figure C5 shows that some participants drove at speeds much higher than 65 mph, which was the posted speed limit in the scenarios on open roadway conditions. Also, all participants drove above the 55 mph speed limit posted just before entering the work zone.

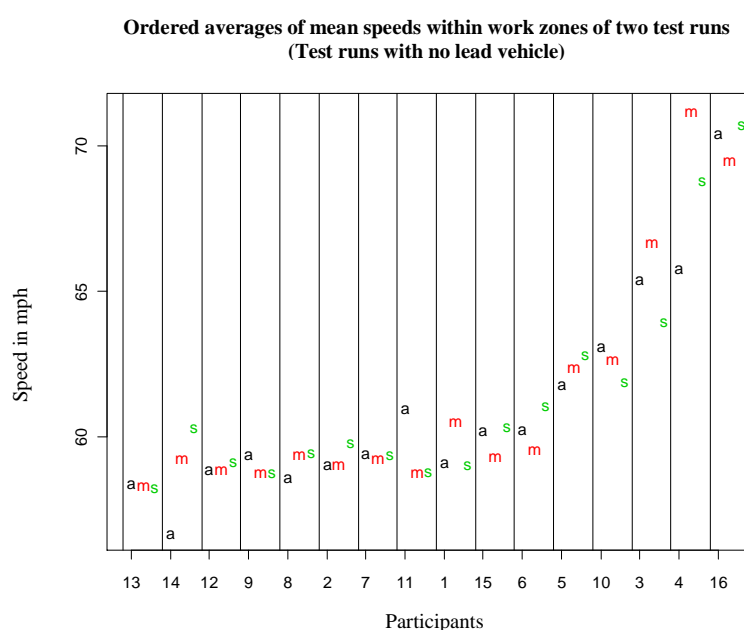

Figure C5 – Ordered averages of mean speeds within work zones
(Test runs without lead vehicle)

Note: The participants are arranged in increasing order of their averaged mean speed.
M – Moving lights; A – Asynchronous lights; S – Static lights

From the analyses of mean speeds in test runs with and without lead vehicle, it was evident that the countermeasure's effect was drastically subdued. This could have also been because the lights were often occluded by the lead vehicle or because the simulator's capacity in generating a life-like beacon was insufficient.

APPENDIX D – ANALYSIS OF INDIVIDUAL SPEED PROFILES

It was expected that participants' speed profiles through work zones with moving lights would be characterized by a lower number of speeding peaks and valleys compared to their speed profiles in work zones with other conditions. This would have been characterized by the obvious lack of sharp undulations in the speed profile and a periodogram with the highest power in the lowest frequencies and comparatively very little power in the higher frequencies. This was, however, not observed among all participants, and most participants' driving profiles remained more or less the same through each work zone in respective test runs. As an example, Figures D1 (without lead vehicle) and D2 (with lead vehicle) show the speed profile of Participant 15-M. In the column titles, the letter M or F after the participant number indicates gender – male or female, respectively; the term “Trial No” indicates the test run (see Appendix B); and “WZ Sequence” indicates the order (see Table B1) in which the work zone types appeared within the test run. The second column in the figures shows the repeated measure. Figure D1 shows that the participant drove around 60 mph during the first trial with some undulations in speed and that the drive through the asynchronous lights condition seems to be the most stable. The speed profile within the moving lights condition has stronger undulations, but it has greater speed reduction and the participant stays around 55 mph toward the later 20 percent of the work zone. In the repeated measure (participant's third test run), the participant ramps up the speed toward the end of the test run, which is, coincidentally, the work zone with the moving lights condition. This time, the drive through the static lights condition is the most stable, but speeds are higher than 60 mph. The drive had the greatest speed reduction within the asynchronous lights condition. The plots show that the data does not provide strong evidence in favor or against greater speed reduction or lesser speed variation in the moving lights condition compared to other conditions.

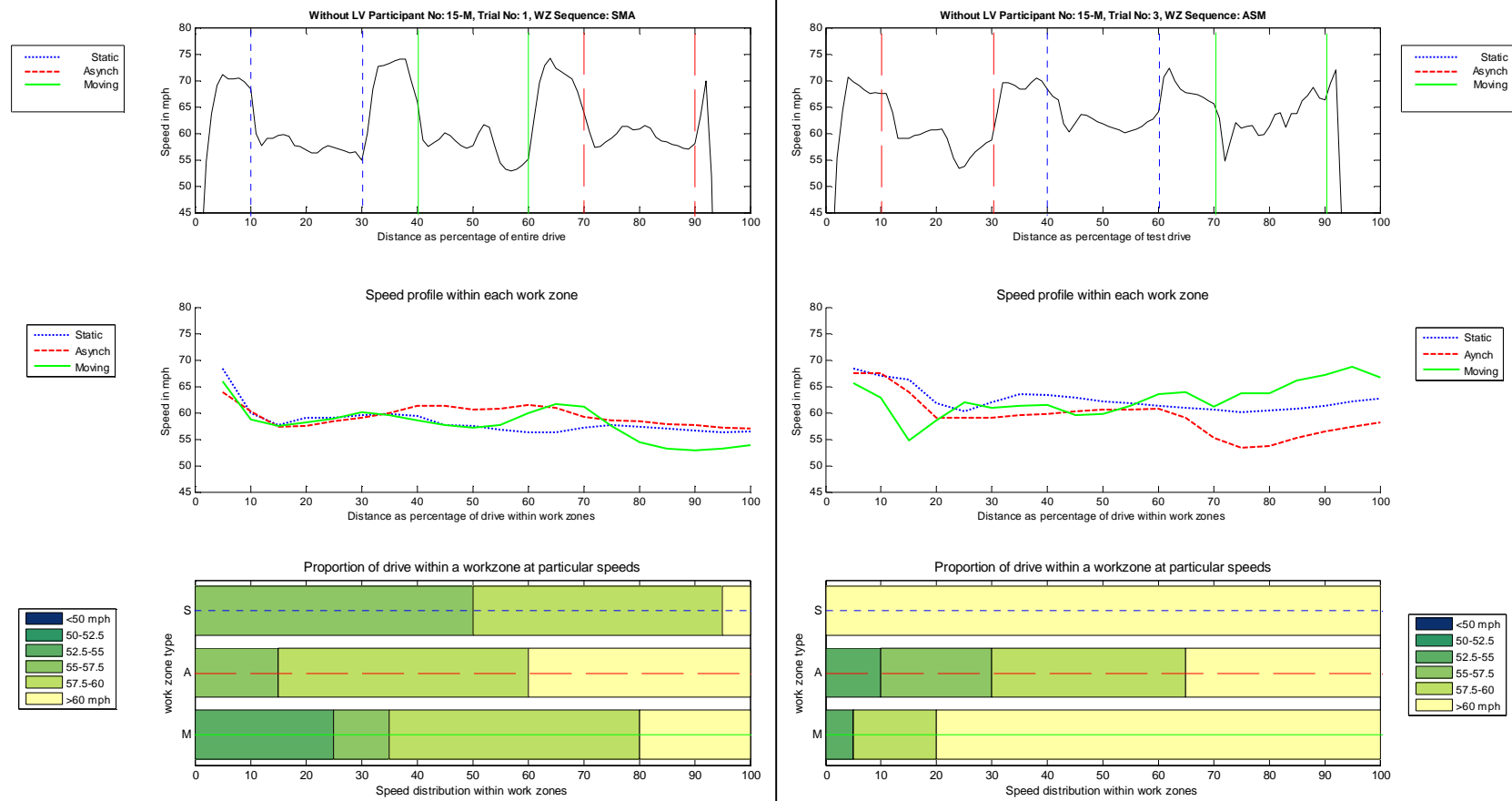

Figure D1 - Speed profile of Participant 15-M in test runs without lead vehicle

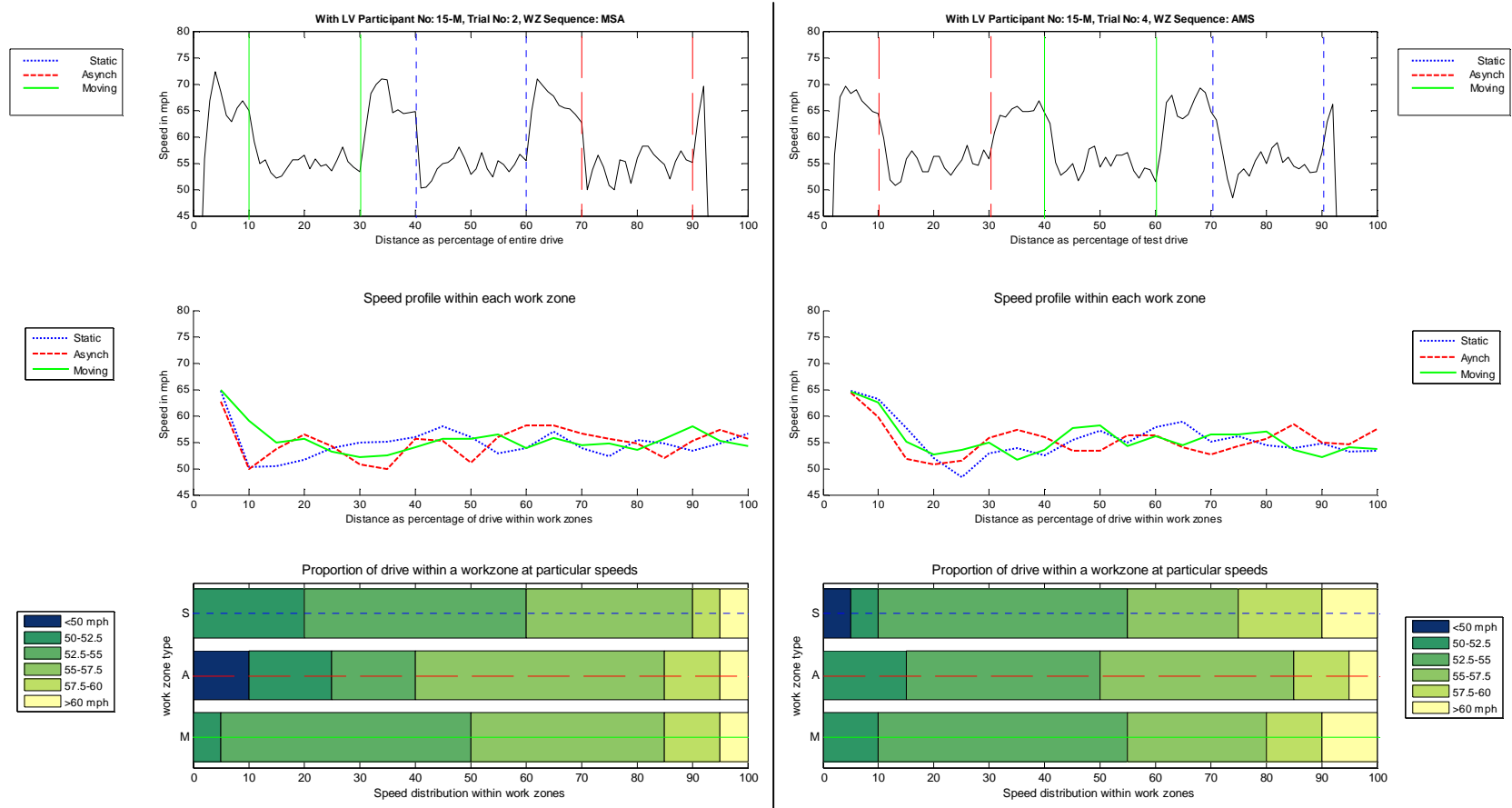

Figure D2 - Speed profile of Participant 15-M in test runs with lead vehicle

APPENDIX E – COMMENTARY

Additional issues of concern included whether the presence of a speedometer influenced the effectiveness of the intervention and if any of the test conditions confused or startled the test subjects. The extent to which the sample means are similar in the task without a lead vehicle is also peculiar. It is reasonable to suspect that participants were motivated to pay more attention to their driving speed due to the flashing warning lights. It can be conceived that additional processing resources vested in a primary task can lead to better performance, however this can also lead to a decrement in subsidiary tasks (Wickens, 1991). Maintaining vehicular attitude – lane position – competes with maintaining vehicular speed. To investigate this, an exploratory analysis of lane-keeping behavior was also conducted because the simulator logged the information by default.

Though no specific hypothesis was formulated regarding the effects of work zones on lane-keeping behavior, an exploratory analysis of the data revealed that participants shied away from the barriers. Figure E1 plots the lane-keeping profile of each participant. This observation has significant implications in work zone design where specific TTC devices or their combinations can be used to create a more effective separation between motorists and the activity area.

Results of analysis of lane-keeping behavior

Participants' deviation within their lanes away from the demarcated work zone could stem from a concern about colliding with the concrete barriers. As identified earlier in the background section, the effect of TTC devices and their combinations is an area that needs more research. Drivers' tendency to shy away from the work zone could also be due to the perceived intensity of work in the work zone. The ability to incorporate the intensity of work at a work zone in a simulator-based study is a general challenge. In the driving scenario, the concrete barriers might have indicated a higher level of activity,

which is the case in the real world, where concrete barriers are mostly used for long-term work zones with greater activity.

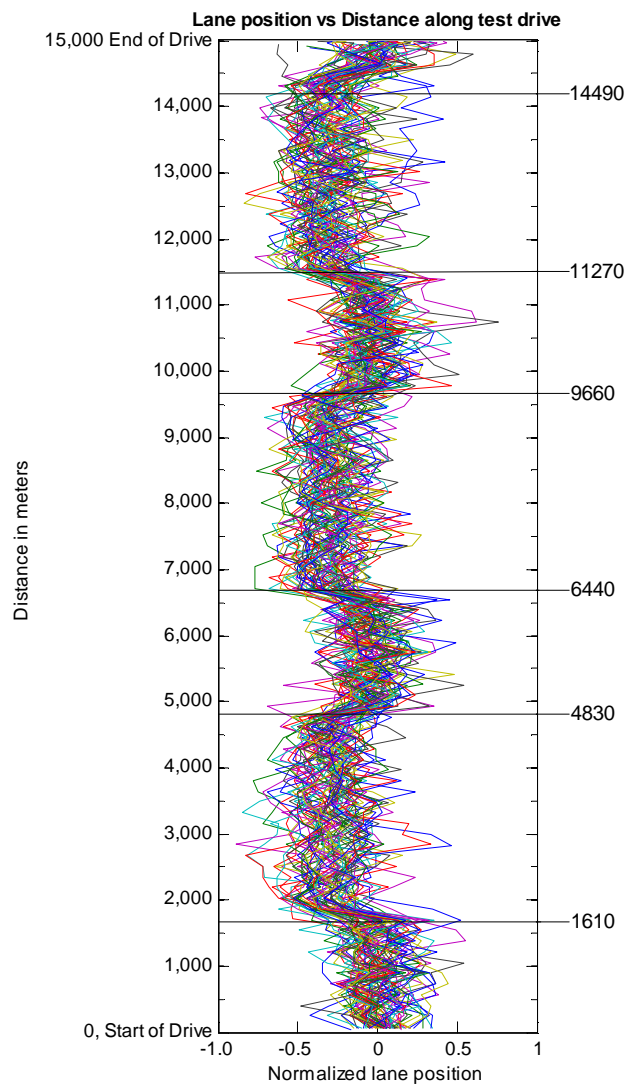

Figure E1 – Lane position versus distance along test drive

REFERENCES

- Aktan, F., Schnell, T., Aktan, M. (2006). Development of Model to Calculate Roadway Luminance Induced by Fixed Roadway Lighting, *Transportation Research Record: Journal of the Transportation Research Board*, 1973, 130-141
- Antonucci, N. D., Hardy, K. K., Bryden, J. E., Neuman, T. R., Pfefer, R. & Slack, K. (2005). *NCHRP Report 500 Vol. 17 – A guide for reduced work zone collisions*. Washington, DC: Transportation Research Board.
- Bai, Yong & Li, Yingfeng (2009). *Reducing Work Zone Crashes by Using Vehicle's Flashers as a Warning Sign, Report No. K-TRAN: KU-07-3*. Topeka, KS: Kansas DOT.
- Barton, J. E., Misener, J. A. & Cohn, T. E. (2002). Computational vision model to asses work zone conspicuity, *Transportation Research Record: Journal of the Transportation Research Board*, 1801, 73-79.
- Beacher, A. G., Fontaine, M. D., & Garber, N. J. (2004). *Evaluation of late merge work zone traffic control strategy, Report No. VTRC 05-R6*. Charlottesville, Virginia: Virginia Transportation Research Council.
- Benekohal, R. F., Kastel, L. M. & Suhale, M. I. (1992). *Evaluation and summary of studies in speed control methods in work zones, Report No. FHWA/IL/UI-237*, Springfield, Illinois: Illinois Department of Transportation - FHWA.
- Benekohal, R. F., Shim, E., Resende, P. T. V. (1995). *Analysis of truck drivers' opinion on safety and traffic control on highway work zones*. Urbana-Champaign, Illinois: University of Illinois Urbana-Champaign. Retrieved March 30, 2009 from <http://www.ict.uiuc.edu/Publications/report%20files/TES-092.pdf>
- Bligh, R. P, Mak, K. K. & Rhodes Jr., L. R. (1998). Crash testing and evaluation of work zone barricades. *Transportation Research Record: Journal of Transportation Research Board*, 1650, 36-44.
- Brewer, M. A., Pesti, G., Schneider, W. VI (2006). Improving compliance with work zone speed limits – Effectiveness of selected devices. *Transportation Research Record: Journal of Transportation Research Board*, 1948, 67 – 76.
- Chitturi, M. V., Benekohal, R. F. & Kaja-Mohideen, A. (2008). Methodology for Computing Delay and User Costs in Work Zones, *Transportation Research Record: Journal of the Transportation Research Board*, 2055, 31-38.
- Darkopoulos, A. & Vergou, G. (2003). *Evaluation of the converging chevron pavement marking pattern on one Wisconsin location*. Washington, DC: AAA Foundation for Traffic Safety.

- Denton, G. G. (1971). *The Influence of Visual Pattern on Perceived Speed* (Report LR409). Crowthorne, Berkshire, UK: Transport and Road Research Laboratory.
- Denton, G. G. (1980). The influence of visual pattern on perceived speed. *Perception*, 9, 393-402.
- Dudek, C.L. & Ullman, G.L. (2002). Flashing Messages, Flashing Lines, and Alternating One Line on Changeable Message Signs. *Transportation Research Record: Journal of the Transportation Research Board*, 1803, 94-101.
- Durkop, B.R., & Dudek, C.L. (2001). Texas Driver Understanding of Abbreviations for Changeable Message Signs. *Transportation Research Record: Journal of the Transportation Research Board*, 1748, 87-95.
- Fields, B., Godley, S., Triggs, T. & Jarvis, J. (1997). *Perceptual Countermeasures: Simulator Validity Study*. Canberra: Federal Office of Road Safety, Road and Traffic Authority of New South Wales
- Finley, M. D., Ullman, G. L. & Dudek, C. L. (2001). Sequential Warning Light System for Lane Closure, *Transportation Research Board 80th Annual Meeting, Paper No. 01-2293*. Washington, DC: Transportation Research Board.
- Fitzsimmons, E., Oneyear, N., Hallmark, S., Hawkins, N. & Maze, T. (2009). *Synthesis of traffic calming techniques in work zones*. Ames, Iowa: CTRE, Iowa State University.
- Fontaine, M. D., Carlson, P. J. & Hawkins Jr., H. G. (2000). *Evaluation of traffic control devices for rural high-speed maintenance work zones: second year activities and final recommendations, Report No. FHWA/TX-01/1879-2*. Austin, Texas: Texas Transportation Institute.
- Fylan, F., Hempel, S., Grunfeld, B., Conner, M. & Lawton, R. (2006). *Effective interventions for speeding motorists, Road Safety Research Report No. 66*. London, UK: Department for Transportation.
- Garber, N.J. and Patel, S.T., (1995). Control of vehicle speeds in temporary traffic control zones (work zones) using changeable message signs with radar. *Transportation Research Record: Journal of the Transportation Research Board*, 1509, 73-81.
- Gibbons, R. B., Lee, S. E., Williams, B. & Miller, C. C. (2008). *NCHRP Report No. 624 – Selection and application of warning lights on roadway operations equipment*, Washington, DC: Transportation Research Board.
- Gibson, J. J. (1950). *The perception of the visual world*. Boston, Massachusetts: Houghton Mifflin.

- Godley, S. T. (1999). Driving simulator study of perceptual countermeasures to speeding, Doctoral Thesis. New South Wales, Australia: University of Monash. Retrieved July 27 2008 from <http://www.psych.usyd.sedu.au/staff/stuartg/GodleyThesis.pdf>
- Griffin, L. I., & Reinhardt, R. N. (1996). *A Review of Two Innovative Pavement Marking Patterns that have been Developed to Reduce Traffic Speeds and Crashes*. Washington, DC: AAA Foundation for Traffic Safety.
- Hoskins, A. H. & El-Gindy, M. (2006). Technical report: Literature survey on driving simulator validation studies, *International Journal of Heavy Vehicle Systems*, Vol. 13, No. 3, 241 – 252.
- Huebschman, C. R., Garcia, C., Bullock, D. M. & Abraham, D. M. (2003). Construction work zone safety, Report No. FHWA/IN/JTRP-2002/34. West Lafayette, Indiana: Purdue University – Indiana DOT – FHWA. Retrieved March 31, 2009 from <http://docs.lib.purdue.edu/jtrp/43>
- Kaptein, N. A., Theeuwes, J. & Van Der Horst, R. (1996) Driving simulator validity: Some considerations, *Transport Research Record Vol. 1550, No. 1*, 30.
- Kamyab, A., McDonald, T., Storm, B., & Anderson-Wilk, M. (2003). *Effectiveness of extra enforcement in construction and maintenance work zones*. Ames, IA: CTRE, Iowa State University.
- Katz, Bryan J. (2004). *Peripheral Transverse Pavement Markings for Speed Control*, PhD. Dissertation. Blacksburg, Virginia: Virginia Polytechnic Institute and State University
- Kim, T., Lovell, D. J. & Park, Y. (2007). Empirical analysis of underlying mechanism and variability in car-following behavior. *Transportation Research Record: Journal of the Transportation Research Board*, 1999, 170-179.
- Larish, J. F. & Flach, J. M. (1990). Sources of optical information useful for perception of speed of rectilinear self-motion, *Journal of Experimental Psychology: Human Perception and Performance*. Vol. 16(2), 295-302
- Lessner, A. (2005). Work Zone Innovations. Paper presented at the 2005 AASHTO Standing Committee on Quality Conference, Washington, DC. In Fitzsimmons, E., Oneyear, N., Hallmark, S., Hawkins, N. & Maze, T. (2009). *Synthesis of traffic calming techniques in work zones*. Ames, Iowa: CTRE, Iowa State University.
- Li, Yingfeng & Bai, Yong (2008). Effectiveness of temporary traffic control measures in highway work zones, *Safety Science Vol. 47*, 453 – 458.

- McGehee, D. V., Lee, J. D., Rizzo, M., Dawson, J. & Bateman, K. (2004). Quantitative analysis of steering adaptation on a high performance fixed-base driving simulator, *Transportation Research Part F, Vol. 7*, 181 – 196.
- Medina, Juan C, Benekohal, Rahim F, Hajbabaie, Ali , Wang, Ming-Heng, & Chitturi, Madhav Vijaya (2009). Downstream Effects of Speed Photo Enforcement and Other Speed Reduction Treatments on Work Zones, *Transportation Research Board 88th Annual Meeting*. Washington, DC: Transportation Research Board
- Meyer, E. (1999). Application of Optical Speed Bars to Highway Work Zones. *Transportation Research Record: Journal of the Transportation Research Board: Journal of the Transportation Research Board, 1657*, 48-54.
- Meyer, E. (2000). *A Literature Review of Perceptual Countermeasures to Speeding*. Lawrence, Kansas: University of Kansas.
- Meyer, E. (2005). *Use of temporary traverse rumble strips in work zones*. Maryland: Maryland State Highway Administration, Office of Traffic and Safety. Retrieved February 22, 2009 from <http://www.sha.state.md.us/safety/oost/trafficsignalsandlaws/WorkZoneSafetyToolbox/04RumbleStrips.pdf>
- Michigan DOT (2003). Field tests of variable speed limits in work zones (in Michigan) final report. Retrieved March 17, 2009 from <http://tig.transportation.org/sites/aashtotig/docs/VSL%20Entire%20Final%20Report.pdf>
- Minnesota DOT (2004). *Evaluation of 2004 dynamic late merge system*. Retrieved March 17, 2009 from <http://www.dot.state.mn.us/trafficeng/workzone/2004DLMS-Evaluation.pdf>
- Mohan, Satish B. & Gautam, Padma (2002). Cost of highway work zone injuries. *Practice Periodical on Structural Design and Construction*.
- Mohan, Satish & Zech, Wesley C., (2005). Characteristics of worker accidents on NYSDOT construction projects, *Journal of Safety Research (36)*, 353 – 360.
- Noel, E. C., Dudek, C. L., Pendelton, O. J., McGee H. W. & Sabra, Z. A. (1987). *Speed control through work zones: Techniques, evaluation and implementation guidelines, Report No. FHWA-IP-87-4*, Washington, DC: FHWA.
- Noel, E. C., Sabra, Z. A. & Dudek, C. L. (1989). *Work zone traffic management synthesis: Use of rumble strips in work zones, Report No. FHWA-TS-89-037*. McLean, Virginia: FHWA – Turner-Fairbank Research Center. Retrieved February 17, 2009 from <http://www.fhwa.dot.gov/tfhrc/safety/pubs/89037/89037.pdf>

- Owen, D. H. (1982). *Optical flow and texture variables useful in simulating self-motion*. (Interim technical report for Contract No. AFSOR 81-0078, Task 61102F 2313/A2). Columbus: The Ohio State University Research Foundation. Retrieved August 16th 2008 from <http://stinet.dtic.mil/cgi-bin/GetTRDoc?AD=ADA117016&Location=U2&doc=GetTRDoc.pdf>
- Pesti, G. & McCoy, P. T. (2007). Long-term effectiveness of speed monitoring displays in work zones on rural interstate highways, *Transportation Research Record: Journal of the Transportation Research Board*, 1764, 20-31.
- Photosensitive Epilepsy, Examples of Triggers*. Retrieved August 2, 2008 from <http://www.epilepsyfoundation.org/about/photosensitivity/>
- Post-Tribune Staff Report (2010). *Charges are expected in Borman hit-and-run*. Retrieved March 15, 2010 from <http://www.post-trib.com/news/2106370,new-crashmain-0317.article>
- Riffkin, M., T. McMurtry, S. Heath, and M. Saito. 2008. *Variable Speed Limit Signs' Effects on Speed and Speed Violation in Work Zones. Report No. UT-08-01*. Salt Lake City, UT: Utah DOT.
- Ross Jr., H. E., Sicking, D. L., Zimmer, R. A. & Michie, J. D. (1993). NCHRP Reptot 350 – Recommended procedures for the safety performance evaluation of highway features. Washington, DC: Transportation Research Board.
- Rudin-Brown, C. M. (2006). The Effect of Driver Eye Height on Speed Choice, Lane-Keeping, and Car-Following Behavior: Results of Two Driving Simulator Studies, *Traffic Injury Prevention*, 7:4, 365 — 372
- Scriba, T., & Luttrell, T. (2004). *Intelligent Transportation Systems in Work Zones: A Case Study - Dynamic Lane Merge System*. Detroit, MI: FHWA - US DOT. Retrieved March 17, 2009 from http://www.itsdocs.fhwa.dot.gov//JPODOCS/REPTS_TE/14011.htm
- Steinman, R. M., Pizlo, Z. & Pizlo F. J. (2000). Phi is not beta and why Wertheimer's discovery launched the Gestalt revolution.
- Stuster, J., Coffman, Z. & Warren, D. (1999). Synthesis of safety research related to speed and speed management, Report No. NO. FHWA-RD-98-154. McLene, Virginia: FHWA – NHTSA. Retrieved February 17, 2009 from <http://www.tfhr.gov/safety/speed/spdtoc.htm>
- The National Work Zone Safety Information Clearinghouse^a. Retrieved July 27 2008 from http://www.workzonesafety.org/training/fhwa_wz_grant/grant_overview

- The National Work Zone Safety Information Clearinghouse^b. Retrieved April 4, 2009
http://www.workzonesafety.org/public_awareness/
- Transportation Statistics Annual Report 2007*. Washington, DC: U.S. Department of Transportation, Research and Innovative Technology Administration, Bureau of Transportation Statistics.
- Ullman, B. R., Ullman, G. L., Dudek, C. L. & Ramirez E. A. (2005). Legibility distance of small letters on changeable message signs with light emitting diodes, *Transportation Research Record: Journal of the Transportation Research Board*, 1918, 56 – 62.
- Ullman, G. L., Finley, M. D., Pike, A. M., et al. (2008a). Studies to improve temporary traffic control at urban freeway interchanges and pavement marking material selection in work zones, Report No. FHWA/TX-08/0-5238-2. Austin, Texas: Texas DOT – FHWA. Retrieved August 5, 2008 from career
<http://ti.tamu.edu/documents/0-5238-2.pdf>
- Ullman, G. L., Finley, M. D., Bryden, J. E., Srinivasan, R. & Council, F. M. (2008b). *NCHRP Report No. 627 – Traffic safety evaluation of nighttime and daytime work zones*. Washington, DC: Transportation Research Board.
- U.S. Rehabilitation Act of 1973, Section 508, Subpart B – Technical Standards*. Retrieved August 2, 2008 from
<http://www.section508.gov/index.cfm?FuseAction=Content&ID=12#Web>
- US DOT – FHWA (1996). Summary report - Uniform traffic control and warning messages for portable changeable message signs, Report No. FHWA-RD-95-173. McLean, Virginia: FHWA – Turner-Fairbank Research Center. Retrieved April 2, 2009 from <http://www.fhwa.dot.gov/tfhrc/safety/pubs/95173/95173.PDF>
- US DOT – FHWA (2007). *FHWA - MUTCD 2003 Edition with Revisions 1 and 2 incorporated*, U.S Department of Transportation, Federal Highway Administration.
- US DOT – FHWA (2008). *Work zone safety and mobility program – fact and statistics*. Retrieved March 24, 2009 from
http://ops.fhwa.dot.gov/wz/resources/facts_stats.htm
- US DOT – FHWA (2009). *Work Zone Safety Factsheet*. Retrieved February 22, 2009 from http://safety.fhwa.dot.gov/wz/wz_facts.htm
- US DOT – NHTSA (2005). *Analysis of Speeding-Related Fatal Motor Vehicle Traffic Crashes, Technical Report No. DOT HS 809 839*. Retrieved February 08 2009 from http://www-nrd.nhtsa.dot.gov/pdf/nrd-30/NCSA/Rpts/2005/809_839/pages/809-839_Final.pdf

- US DOT – NHTSA (2008). *National Motor Vehicle Crash Causation Survey Report to Congress, Report No. DOT HS 811 059*. Retrieved February 12, 2009 from http://www.nhtsa.dot.gov/portal/nhtsa_static_file_downloader.jsp?file=/staticfiles/DOT/NHTSA/NCSA/Content/NMVCCS/811059.pdf
- US DOT – NHTSA (2009). *Fact Sheet - Speeding, Report No. DOT HS 810 998*. Retrieved February 08 2009 from http://www.nhtsa.dot.gov/portal/nhtsa_static_file_downloader.jsp?file=/staticfiles/DOT/NHTSA/NCSA/Content/TSF/2007/810998.pdf
- Vercuysen, M., Williams, G., Wade, M. G. (1995). *Lighted guidance devices: Intelligent work zone traffic control, Report No. MN/RC - 96/05*, St. Paul, Minnesota: Minnesota Department of Transportation Office of Research Administration.
- Voigt, A. P., & Kuchangi, S. P. (2008). *Evaluation of chevron marking on freeway-to-freeway connector ramps in Texas (Report 0-813-2)*. Collage Station, Texas: Texas Transportation Institute.
- Warren, R. (1982). *Optical transformations during movement: Review of the optical concomitants of egospeed. (Final technical report for Grant No. AFOSR-81-0108)*. Columbus: Ohio State University, Department of Psychology, Aviation Psychology Laboratory. In Larish, J. F. & Flach, J. M. (1990). Sources of optical information useful for perception of speed of rectilinear self-motion. *Journal of Experimental Psychology: Human Perception and Performance*. Vol. 16(2), 295-302
- Wang, C., Dixon, K. K. & David, D. (2007). Evaluating speed-reduction strategies for highway work zones, *Transportation Research Record: Journal of the Transportation Research Board*, 1824, 44-53.
- Wang, J., Hesar, S. G., & Collyer, C. E. (2007). Adding graphics to message sign messages, *Transportation Research Record: Journal of the Transportation Research Board*, 2018, 63 – 71.
- Washington, S., Schalkwyk, I. V., Mitra, S., Meyer, M., Dumbaugh, E. & Zoll, M. (2006). NCHRP Report No. 546 – Incorporating safety into long-range transportation planning. Washington, DC: Transportation Research Board.
- Wickens, C. D. (1991). Processing resources and attention. In D. L. Damos, *Multiple-task performance*. London: Taylor & Francis
- Zwahlen, H. T. & Schnell, T. (1997). Visual detection and recognition of fluorescent color targets versus nonfluorescent color targets as a function of peripheral viewing angle and target size, *Transportation Research Record: Journal of the Transportation Research Board*, 1605, 28-40.

Zwahlen, H. T. & Schnell, T. (1999). Driver Preview Distances at Night Based on Driver Eye Scanning Recordings as a Function of Pavement Marking Retroreflectivities, *Transportation Research Record: Journal of the Transportation Research Board*, 1692, 129-141.